

# HYDROSTATIC STEERING UNITS TYPE HKUS.../3, 4, 8

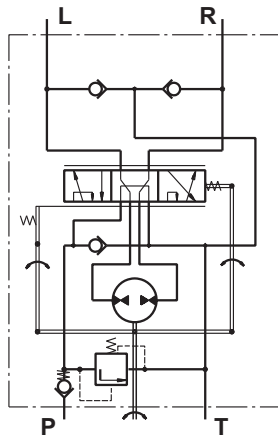

The HKUS Hydrostatic Steering unit is based on the HKU unit but has built-in relief and check valves. Thus M+S Hydraulic achieves one very compact steering unit which reduces the need for additional hydraulic components in the system.



"Open Center - Load Reaction"  
HKUS.../3

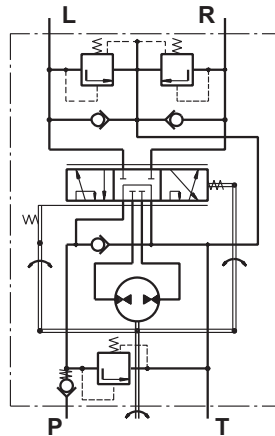

"Open Center - Non Load Reaction"  
HKUS.../4

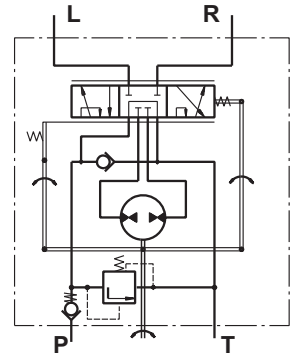

"Open Center - Non Load Reaction"  
HKUS.../8

## SPECIFICATION DATA

Parameters	Type													
	HKUS 40/3,4,8	HKUS 50/3,4,8	HKUS 63/3,4,8	HKUS 80/3,4,8	HKUS 100/3,4,8	HKUS 125/3,4,8	HKUS 160/3,4,8	HKUS 200/3,4,8	HKUS 250/3,4,8	HKUS 320/3,4,8	HKUS 400/3,4,8	HKUS 500/3,4,8		
Displacement	cm <sup>3</sup> /rev [in <sup>3</sup> /rev]	39,6 [2.42]	49,5 [3.0]	65,6 [4.0]	79,2 [4.83]	99,0 [6.04]	123,8 [7.56]	158,4 [9.67]	198 [12.1]	247,5 [15.1]	316,8 [19.3]	396 [24.2]	495 [30.2]	
Rated Flow*	lpm [GPM]	4 [1.1]	5 [1.3]	6 [1.6]	8 [2.1]	10 [2.6]	13 [3.4]	16 [4.2]	20 [5.3]	25 [6.6]	32 [8.4]	40 [10.6]	50 [13.2]	
Rated Pressure	bar [PSI]	140 [2030]		170 [2465]										
Relief Valve Pressure		80		100	125	150	170							
Settings**	bar [PSI]	[1160]		[1450]	[1810]	[2175]	[2465]							
Shock Valves Pressure		140		160	180	200	220							
Settings***	bar [PSI]	[2030]		[2320]	[2610]	[2900]	[3190]							
Max. Cont. Pressure in Line T	bar [PSI]	25 [363] (50 [725] by HKUS.../8)												
	- standard													
	- high pressure (H option)	40 [580]												
Max. Torque at Servoamplifying	Nm [lb-in]	3,0 [26]					-			3,0 [26]				
	- with standard springs													
	- with soft springs (LT option)	1,8 [16]												
Max. Torque w/o Servoamplifying	Nm [lb-in]	120 [1065]												
Weight	kg [lb]	5,3 [11.7]	5,4 [11.9]	5,5 [12.2]	5,6 [12.4]	5,7 [12.6]	5,8 [12.8]	6,0 [13.2]	6,3 [13.9]	6,5 [14.3]	7,0 [15.4]	7,4 [16.3]	8,0 [17.6]	
Dimension A	mm [in]	130,8 [5.15]	132,2 [5.20]	133,9 [5.27]	136,2 [5.36]	138,8 [5.47]	142,2 [5.60]	146,8 [5.78]	152,2 [5.99]	158,8 [6.25]	168,2 [6.62]	178,8 [7.04]	192 [7.56]	

\* Rated Flow at 100 RPM.

\*\* Pressure Settings are at Rated Flow (as in the table) and viscosity 21 mm<sup>2</sup>/s [105 SUS] at 50°C [122°F].

\*\*\* Pressure Settings are at flow rate of 2 lpm [.53 GPM] and viscosity 21 mm<sup>2</sup>/s [105 SUS] at 50°C [122°F].

**DIMENSIONS AND MOUNTING DATA - HKUS.../3, 4, 8**

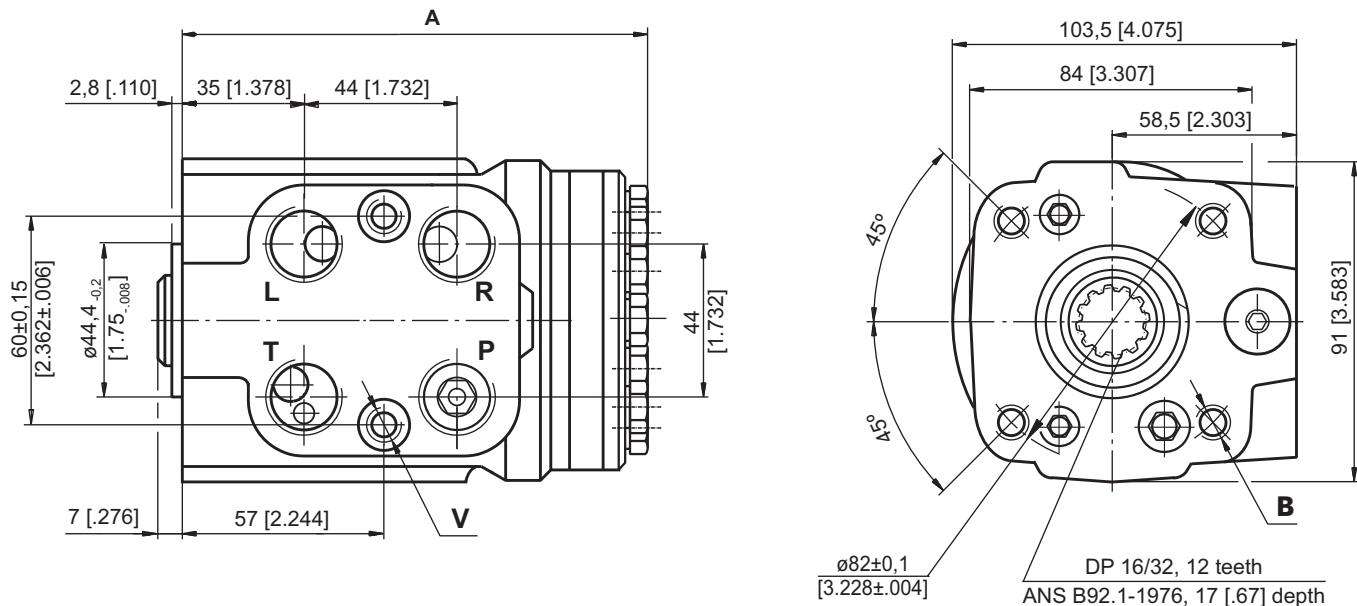

Code	Ports - P*, T, R, L Thread	Column Mounting Thread - B	Valve Mounting Thread - V
-	G1/2 17 [.67] depth	4 x M10 18 [.71] depth	2 x M10x1 16 [.63] depth
M	M22x1,5 17 [.67] depth	4 x M10 18 [.71] depth	2 x M10x1 16 [.63] depth
A	3/4 - 16 UNF O-ring 17 [.67] depth	4 x 3/8 - 16 UNC 15,7 [.62] depth	2 x 3/8 - 24 UNF 14,2 [.56] depth

\*Threaded Ports P min 15 [.59] depth for pipe mounting.

# STEERING UNITS

## ORDER CODE

	1	2	3	4	5	6	7	8
<b>HKU</b>		/	-					

**Pos.1 - Displacement code** (see Specification Data)

- 40** - 39,6 cm<sup>3</sup>/rev [2.42 in<sup>3</sup>/rev]
- 50** - 49,5 cm<sup>3</sup>/rev [3.00 in<sup>3</sup>/rev]
- 63** - 65,6 cm<sup>3</sup>/rev [4.00 in<sup>3</sup>/rev]
- 80** - 79,2 cm<sup>3</sup>/rev [4.83 in<sup>3</sup>/rev]
- 100** - 99,0 cm<sup>3</sup>/rev [6.04 in<sup>3</sup>/rev]
- 125** - 123,8 cm<sup>3</sup>/rev [7.56 in<sup>3</sup>/rev]
- 160** - 158,4 cm<sup>3</sup>/rev [9.67 in<sup>3</sup>/rev]
- 200** - 198,0 cm<sup>3</sup>/rev [12.10 in<sup>3</sup>/rev]
- 250** - 247,5 cm<sup>3</sup>/rev [15.10 in<sup>3</sup>/rev]
- 320** - 316,8 cm<sup>3</sup>/rev [19.30 in<sup>3</sup>/rev]
- 400** - 396,0 cm<sup>3</sup>/rev [24.20 in<sup>3</sup>/rev]
- 500** - 495,0 cm<sup>3</sup>/rev [30.20 in<sup>3</sup>/rev]
- 630** - 623,6 cm<sup>3</sup>/rev [38.05 in<sup>3</sup>/rev]
- 800** - 793,0 cm<sup>3</sup>/rev [48.40 in<sup>3</sup>/rev]
- 1000** - 990,0 cm<sup>3</sup>/rev [60.40 in<sup>3</sup>/rev]

**Pos.2 - Versions**

- 3** - Version 3 "Open Center - Load Reaction"
- 4** - Version 4 "Open Center - Non Load Reaction"
- 7** - Version 7 "Closed Center - Non Load Reaction"

**Pos.3 - Ports**

- omit - BSPP (ISO 228)
- M** - Metric (ISO 262)
- A** - SAE (ANSI B 1.1 - 1982)
- BA\*** - SAE (ANSI B 1.1 - 1982)

**Pos.4 - Max. Cont. Pressure in line T**

- omit - Standard
- H** - High pressure

**Pos.5 - Input torque**

- omit - Standard
- LT\*** - Low

**Pos.6 - Noise level**

- omit - Standard
- LN\*** - Low

**Pos.7 - Option (Paint)\*\*\***

- omit - No Paint
- P** - Painted
- PC** - Corrosion Protected Paint
- PS** - Special Paint\*\*\*\*
- PCS** - Special Corrosion Protected Paint\*\*\*\*

**Pos.8 - Design Series**

- omit - Factory specified

**Notes:**  
 \* Available only for displacement from 40 to 200.  
 \*\* Available only for versions 3 and 4 with displacement from 40 to 200.  
 \*\*\* Colour at customer's request.  
 \*\*\*\* Non painted feeding surfaces, colour at customer's request.

The steering units are manganophosphatized as standard.

## ORDER CODE

	1	2	3	4	5	6	7	8	9
<b>HKUS</b>		/	-	-					

**Pos.1 - Displacement code** (see Specification Data)

- 40** - 39,6 cm<sup>3</sup>/rev [2.42 in<sup>3</sup>/rev]
- 50** - 49,5 cm<sup>3</sup>/rev [3.00 in<sup>3</sup>/rev]
- 63** - 65,6 cm<sup>3</sup>/rev [4.00 in<sup>3</sup>/rev]
- 80** - 79,2 cm<sup>3</sup>/rev [4.83 in<sup>3</sup>/rev]
- 100** - 99,0 cm<sup>3</sup>/rev [6.04 in<sup>3</sup>/rev]
- 125** - 123,8 cm<sup>3</sup>/rev [7.56 in<sup>3</sup>/rev]
- 160** - 158,4 cm<sup>3</sup>/rev [9.67 in<sup>3</sup>/rev]
- 200** - 198,0 cm<sup>3</sup>/rev [12.10 in<sup>3</sup>/rev]
- 250** - 247,5 cm<sup>3</sup>/rev [15.10 in<sup>3</sup>/rev]
- 320** - 316,8 cm<sup>3</sup>/rev [19.30 in<sup>3</sup>/rev]
- 400** - 396,0 cm<sup>3</sup>/rev [24.20 in<sup>3</sup>/rev]
- 500** - 495,0 cm<sup>3</sup>/rev [30.20 in<sup>3</sup>/rev]

**Pos.2 - Versions**

- 3** - Version 3 "Open Center - Load Reaction"
- 4** - Version 4 "Open Center - Non Load Reaction"
- 8** - Version 8 "Open Center - Non Load Reaction"

**Pos.3 - Relief Valve Pressure Settings, bar**

**80, 100, 125, 150, 170**

**Pos.4 - Ports**

- omit - BSPP (ISO 228)
- A** - SAE (ANSI B 1.1 - 1982)
- M** - Metric (ISO 262)

**Pos.5 - Max. Cont. Pressure in line T**

- omit - Standard
- H** - High pressure

**Pos.6 - Input torque**

- omit - Standard
- LT\*** - Low

**Pos.7 - Noise level**

- omit - Standard
- LN\*** - Low

**Pos.8 - Option (Paint)\*\*\***

- omit - No Paint
- P** - Painted
- PC** - Corrosion Protected Paint
- PS** - Special Paint\*\*\*\*
- PCS** - Special Corrosion Protected Paint\*\*\*\*

**Pos.9 - Design Series**

- omit - Factory specified

Version	Manual Steering Check Valve	Relief Valve	Inlet Check Valve	Cylinder Relief Valve	Anti-Cavitation Valve
3	•	•	•		•
4	•	•	•	•	•
8	•	•	•		

**Notes:**  
 \* Available only for displacement from 40 to 200.  
 \*\* Colour at customer's request.  
 \*\*\* Non painted feeding surfaces, colour at customer's request.

The steering units are manganophosphatized as standard.