

HYDRAULIC MOTORS TMF

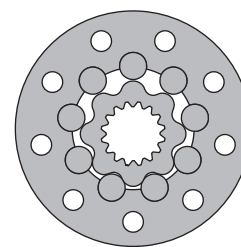

APPLICATION

- » Marine equipment
- » Forestry equipment
- » Metal working machines
- » Agriculture machines
- » Road building machines
- » Mining machinery
- » Special vehicles etc.

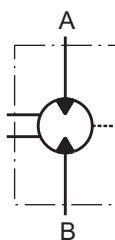

CONTENTS

Specification data	35
Function diagrams	36÷39
Dimensions and mounting TMF.....	40
Dimensions and mounting TMFA	41
Permissible shaft loads	42
Order code	42

OPTIONS

- » Model- Disc valve, roll-gerotor
- » Wheel mounting flange
- » Side ports
- » Shaft- thread hole flange
- » SAE and BSPP ports
- » Other special features

GENERAL

Max. Displacement, cm ³ /rev [in ³ /rev]	724,3 [44.2]
Max. Speed, [RPM]	750
Max. Torque, daNm [lb-in]	cont.: 175 [15490] int.: 215 [16030]
Max. Output, kW [HP]	70 [94]
Max. Pressure Drop, bar [PSI]	cont.: 250 [3600] int.: 350 [5080]
Max. Oil Flow, lpm [GPM]	150 [40]
Min. Speed, [RPM]	5
Permissible Shaft Loads daN [lbs]	P _a =1000 [2250]
Pressure fluid	Mineral based- HLP(DIN 51524) or HM(ISO 6743/4)
Temperature range, °C [°F]	-40÷140 [-40÷284]
Optimal Viscosity range, mm ² /s [SUS]	20÷75 [98÷347]
Filtration	ISO code 20/16 (Min. recommended fluid filtration of 25 micron)

Oil flow in drain line

Pressure drop bar [PSI]	Viscosity mm ² /s [SUS]	Oil flow in drain line lpm [GPM]
200 [2900]	20 [98]	2,5 [.660]
	35 [164]	1,5 [.400]
275 [3990]	20 [98]	4 [1.057]
	35 [164]	2,5 [.660]

Pressure Losses

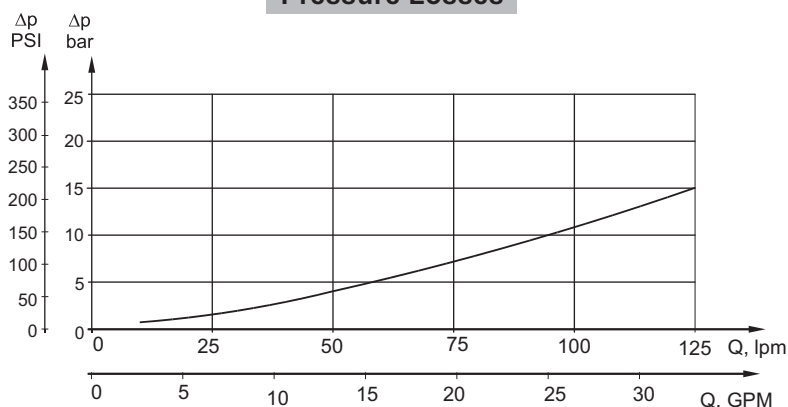

SPECIFICATION DATA

Type	TMF 200	TMF 250	TMF 315	TMF 400	TMF 470	TMF 500	TMF 630	TMF 725
Displacement, cm³/rev [in³/rev]	201,4 [12.29]	251,8 [15.36]	326,3 [19.9]	410,9 [25.06]	475 [28.97]	523,6 [31.95]	631,2 [38.52]	724 [44.2]
Max. Speed, [RPM]	Cont.	625	500	380	305	260	240	185
	Int.*	750	600	460	365	315	285	225
Max. Torque daNm [lb-in]	Cont.	74 [6550]	90[7965]	116[10265]	147[13010]	171[15135]	172[15225]	175[15490]
	Int.*	102 [9030]	128[11330]	163[14425]	206[18232]	215[16030]	215[19030]	215[19030]
	Peak**	115[10180]	144[12745]	186[16460]	235[20800]	240[21240]	240[21240]	250[21225]
Max. Output kW [HP]	Cont.	41 [55]	41 [55]	41 [55]	41 [55]	41 [55]	37,5 [50]	28 [37,5]
	Int.*	65 [87]	70 [94]	70 [94]	70 [94]	55 [74]	51 [68]	42 [56]
Max. Pressure Drop bar [PSI]	Cont.	250[3600]	250[3600]	250[3600]	250[3600]	250[3600]	230[3340]	185[2680]
	Int.*	350[5080]	350[5080]	350[5080]	350[5080]	350[5080]	280[4060]	225[3260]
	Peak**	400[5800]	400[5800]	400[5800]	400[5800]	400[5800]	320[4640]	270[3915]
Max. Oil Flow lpm [GPM]	Cont.	125[33]	125[33]	125[33]	125[33]	125[33]	125[33]	125[33]
	Int.*	150[40]	150[40]	150[40]	150[40]	150[40]	150[40]	150[40]
Max. Inlet Pressure bar [PSI]	Cont.	270[3920]	270[3920]	270[3920]	270[3920]	270[3920]	270[3920]	270[3920]
	Int.*	370[5370]	370[5370]	370[5370]	370[5370]	370[5370]	370[5370]	370[5370]
	Peak**	420[6100]	420[6100]	420[6100]	420[6100]	420[6100]	420[6100]	420[6100]
Max. Return Pressure without Drain Line or Max. Pressure in Drain Line, bar [PSI]	Cont. 0-100 RPM	75 [1100]	75 [1100]	75 [1100]	75 [1100]	75 [1100]	75 [1100]	75 [1100]
	Cont. 100-300 RPM	40 [580]	40 [580]	40 [580]	40 [580]	40 [580]	40 [580]	40 [580]
	Cont. >300 RPM	20 [290]	20 [290]	20 [290]	20 [290]	20 [290]	-	-
	Int.* 0-max. RPM	75 [1100]	75 [1100]	75 [1100]	75 [1100]	75 [1100]	75 [1100]	75 [1100]
Max. Return Pressure with Drain Line bar [PSI]	Cont.	140[2000]	140[2000]	140[2000]	140[2000]	140[2000]	140[2000]	140[2000]
	Int.*	175[2500]	175[2500]	175[2500]	175[2500]	175[2500]	175[2500]	175[2500]
	Peak**	210[3000]	210[3000]	210[3000]	210[3000]	210[3000]	210[3000]	210[3000]
Max. Starting Pressure with Unloaded Shaft, bar [PSI]	6 [90]	6 [90]	6 [90]	6 [90]	6 [90]	6 [90]	6 [90]	6 [90]
Min. Starting Torque daNm [lb-in]	60[5310]	75[6640]	97[8585]	122[10800]	142[12570]	143[12655]	145[12830]	148[13100]
Min. Speed***, [RPM]	5	5	5	5	5	5	5	5
Weight, kg [lb]	26,9[59.3]	27,3[60.2]	28,1[62]	29 [64]	29,7[65.5]	30,2[66.6]	29,7[65.5]	31[68.4]

* Intermittent operation: the permissible values may occur for max. 10% of every minute.

** Peak load: the permissible values may occur for max. 1% of every minute.

*** For speeds lower than given, consult factory or your regional manager.

- Intermittent speed and intermittent pressure must not occur simultaneously.
- Recommended filtration is per ISO cleanliness code 20/16. A nominal filtration of 25 micron or better.
- Recommend using a premium quality, anti-wear type mineral based hydraulic oil, HLP(DIN51524) or HM(ISO6743/4). If using synthetic fluids consult the factory for alternative seal materials.
- Recommended minimum oil viscosity 70 SUS [13 cm²/s] at 50°C [122°F].
- Recommended maximum system operating temperature is 82°C [180°F].
- To assure optimum motor life fill with fluid prior to loading and run at moderate load and speed for 10-15 minutes.

FUNCTION DIAGRAMS

TMF 200

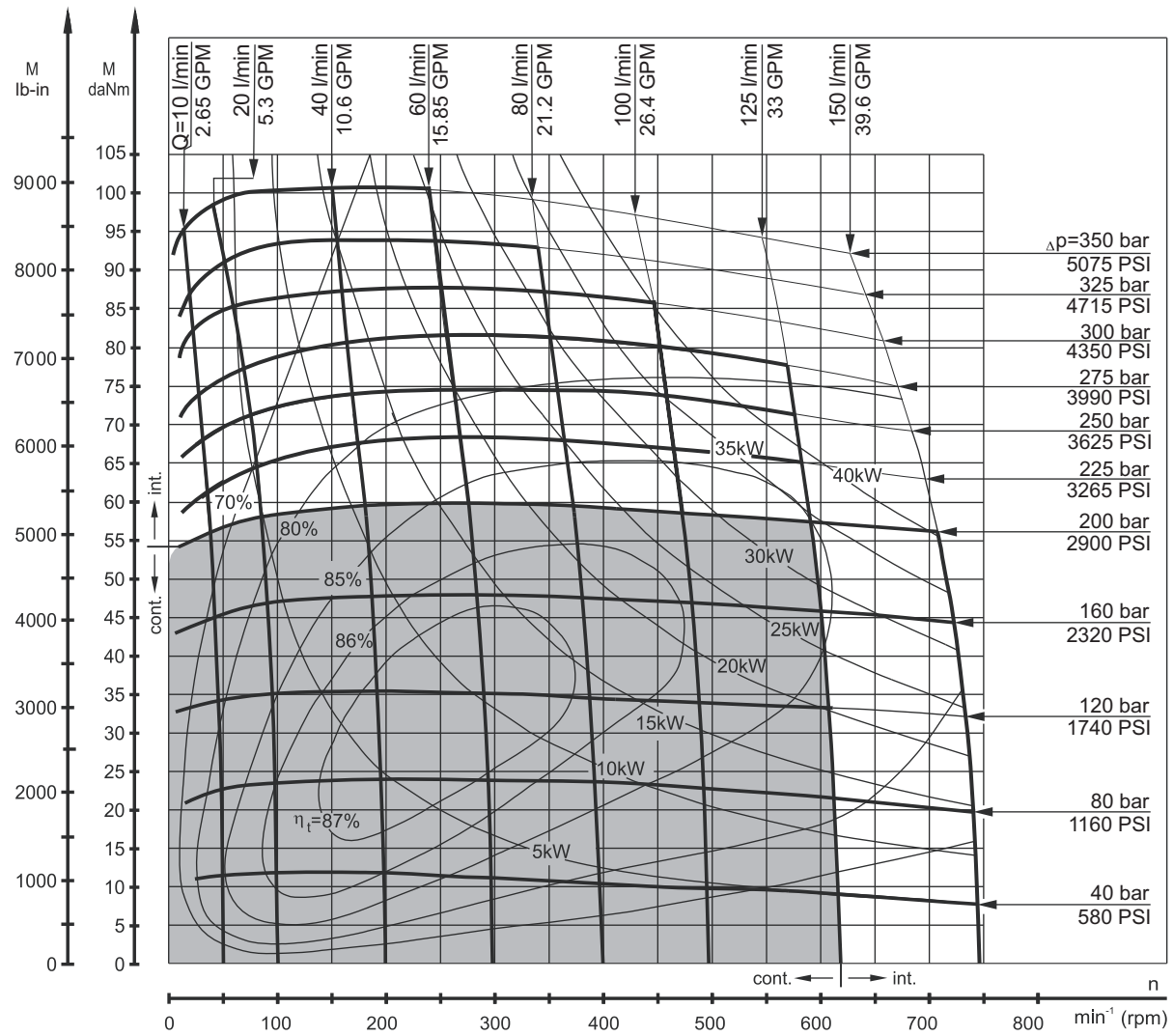

TMF 250

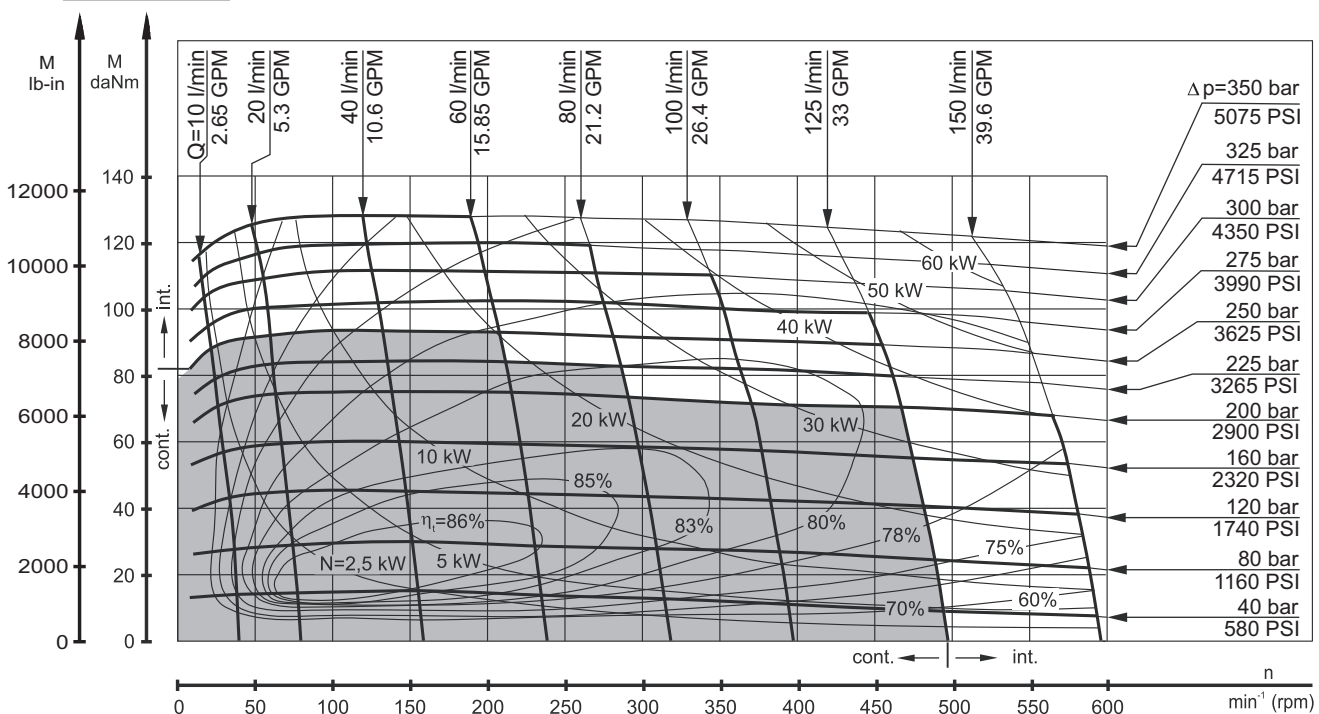

The function diagrams data was collected at back pressure 5÷10 bar (72.5 PSI÷145 PSI) and oil with viscosity of 32 mm²/s [150 SUS] at 50°C [122°F].

FUNCTION DIAGRAMS

TMF 315

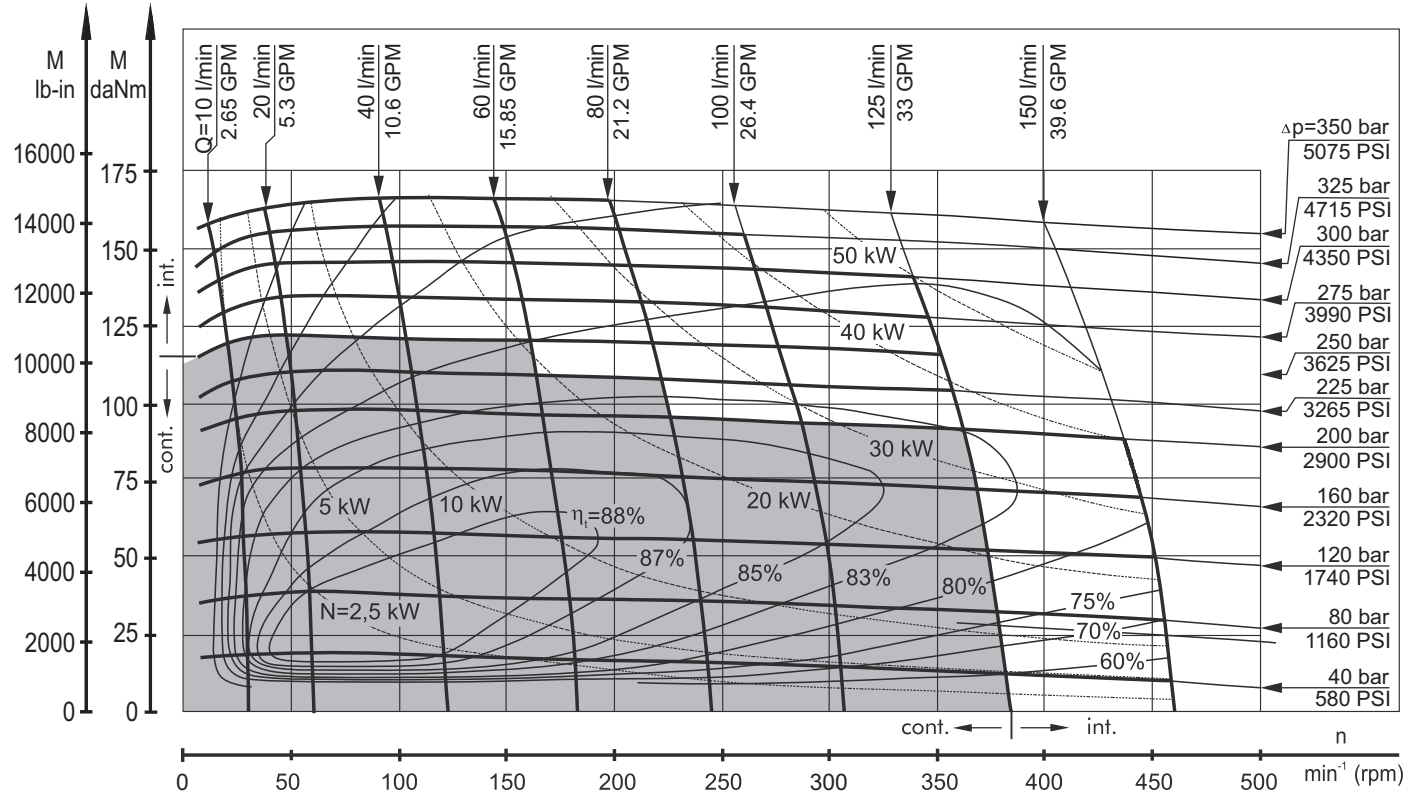

TMF 400

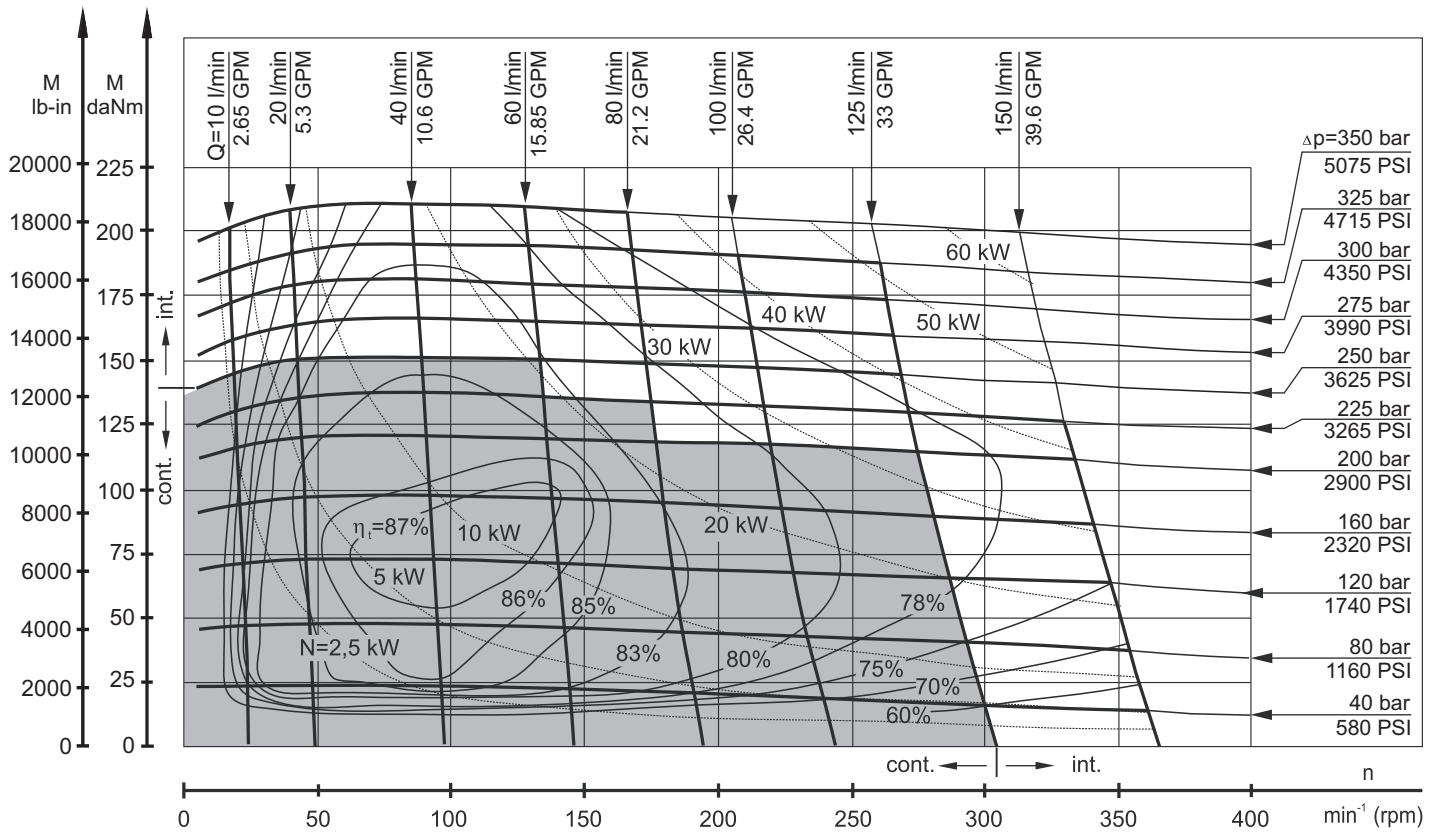

The function diagrams data was collected at back pressure 5÷10 bar (72.5 PSI÷145 PSI) and oil with viscosity of 32 mm²/s [150 SUS] at 50°C [122°F].

FUNCTION DIAGRAMS

TMF 470

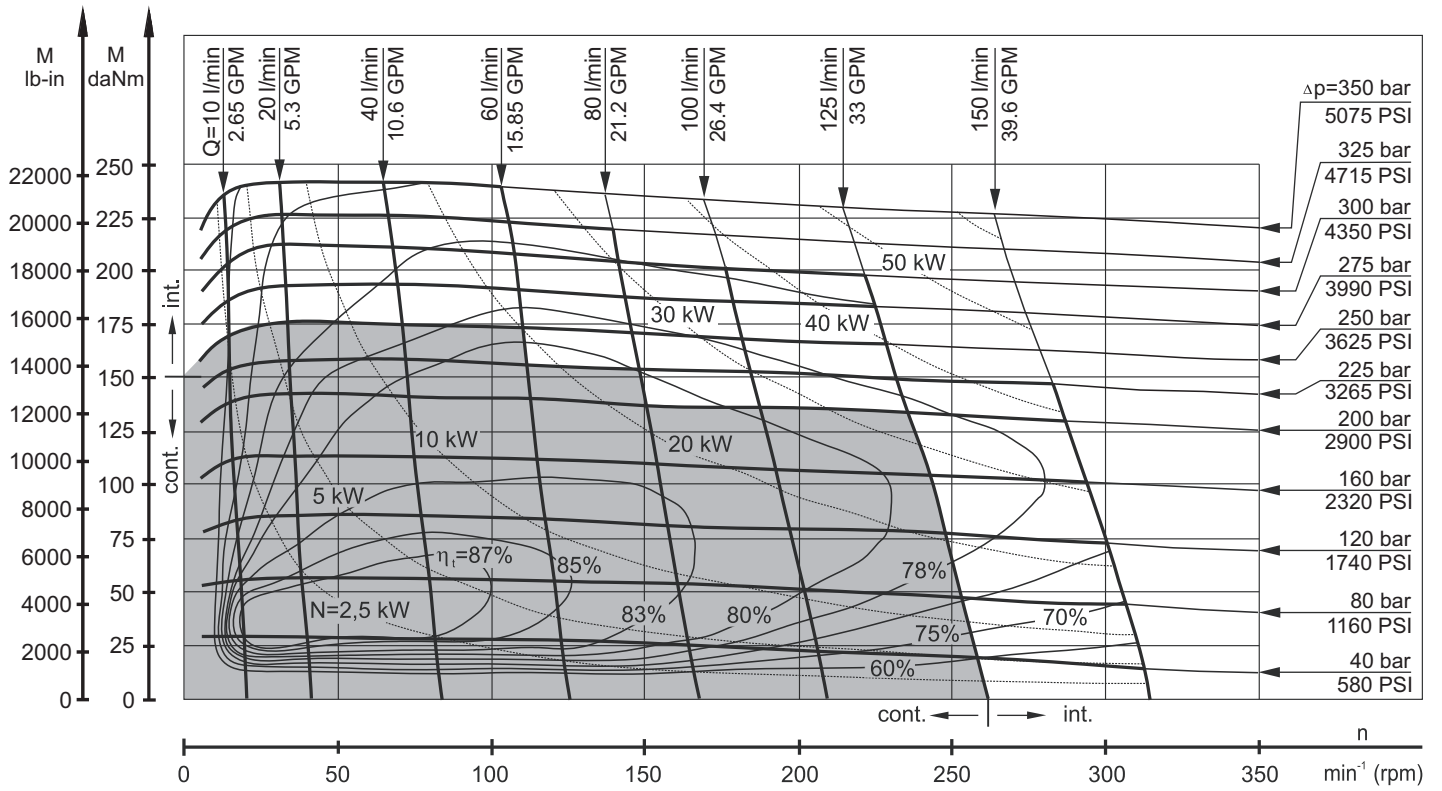

TMF 500

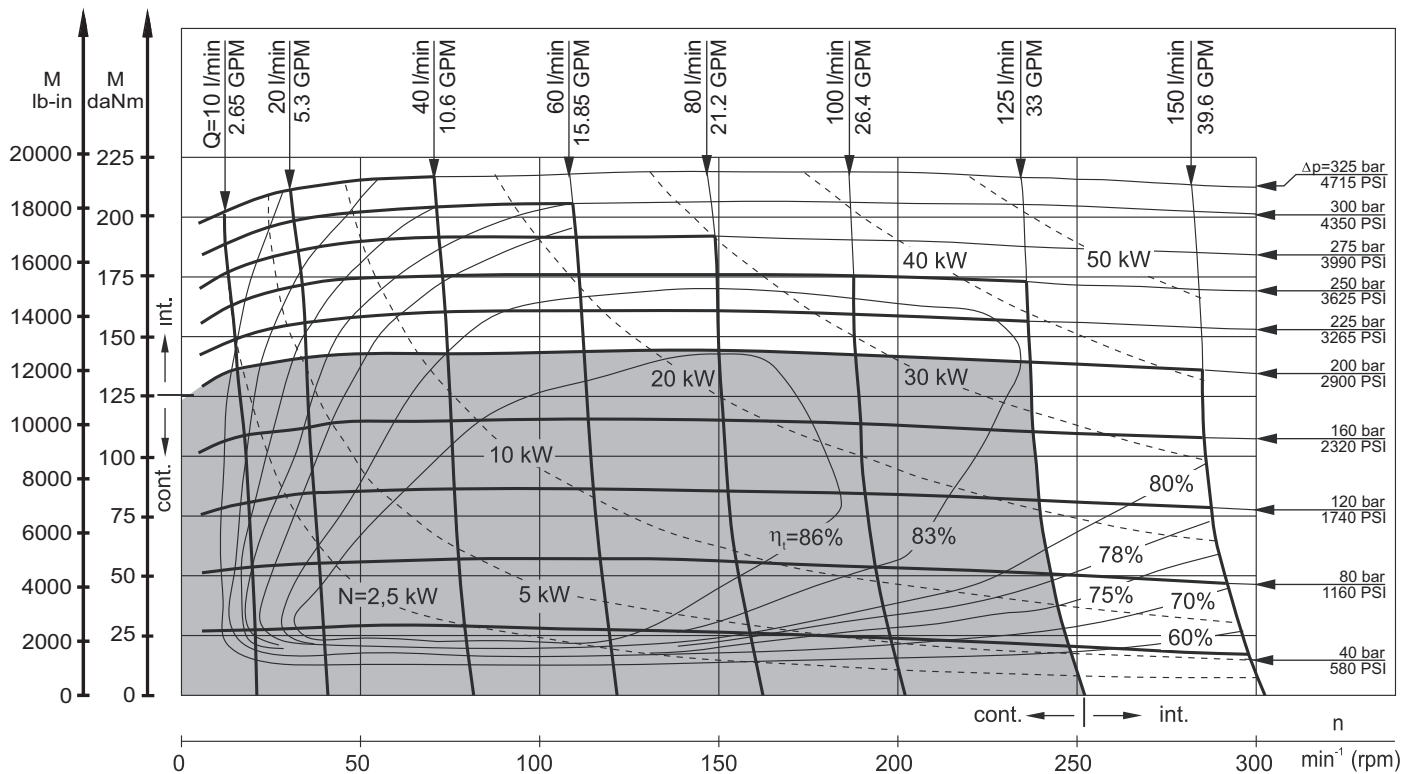

The function diagrams data was collected at back pressure 5÷10 bar (72.5 PSI÷145 PSI) and oil with viscosity of 32 mm²/s [150 SUS] at 50°C [122°F].

FUNCTION DIAGRAMS

TMF 630

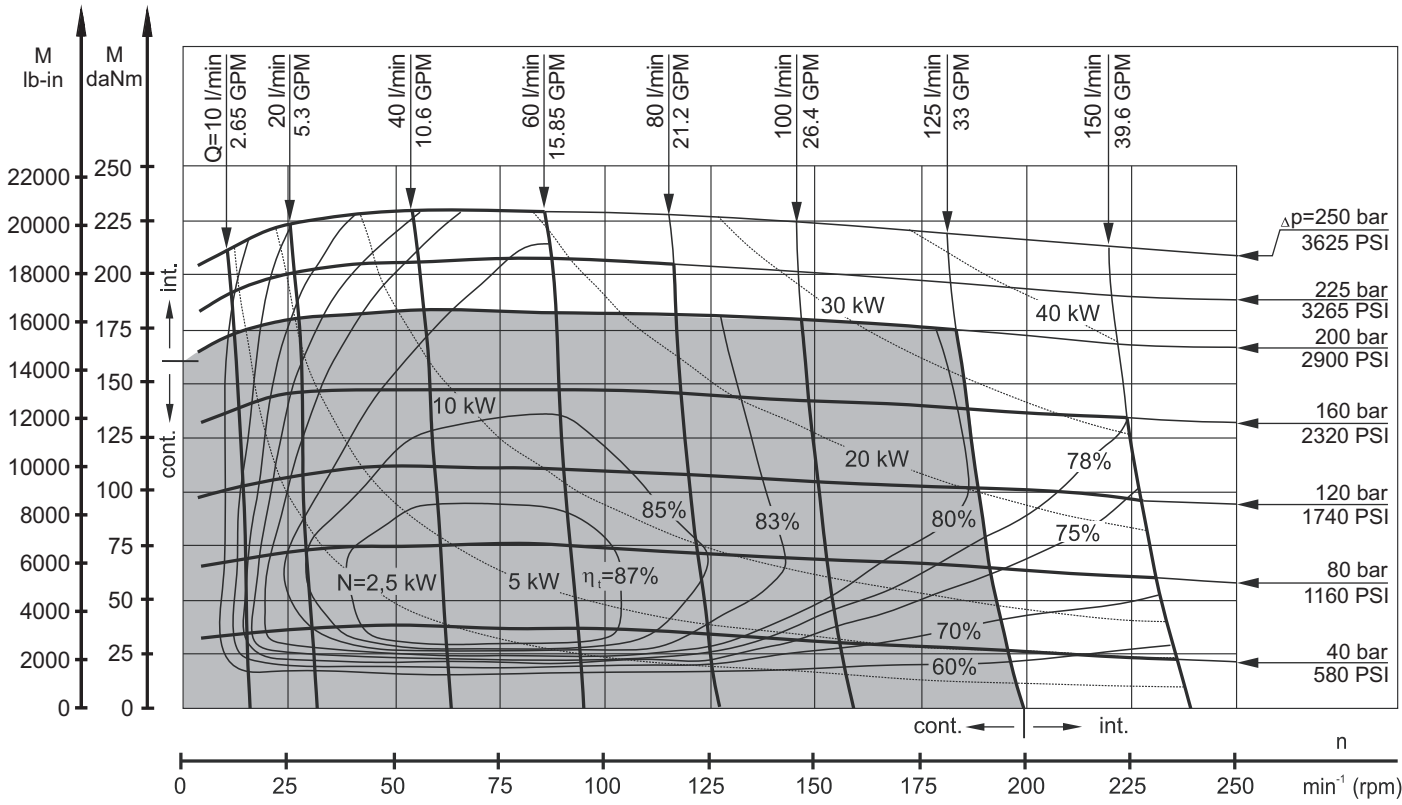

TMF 725

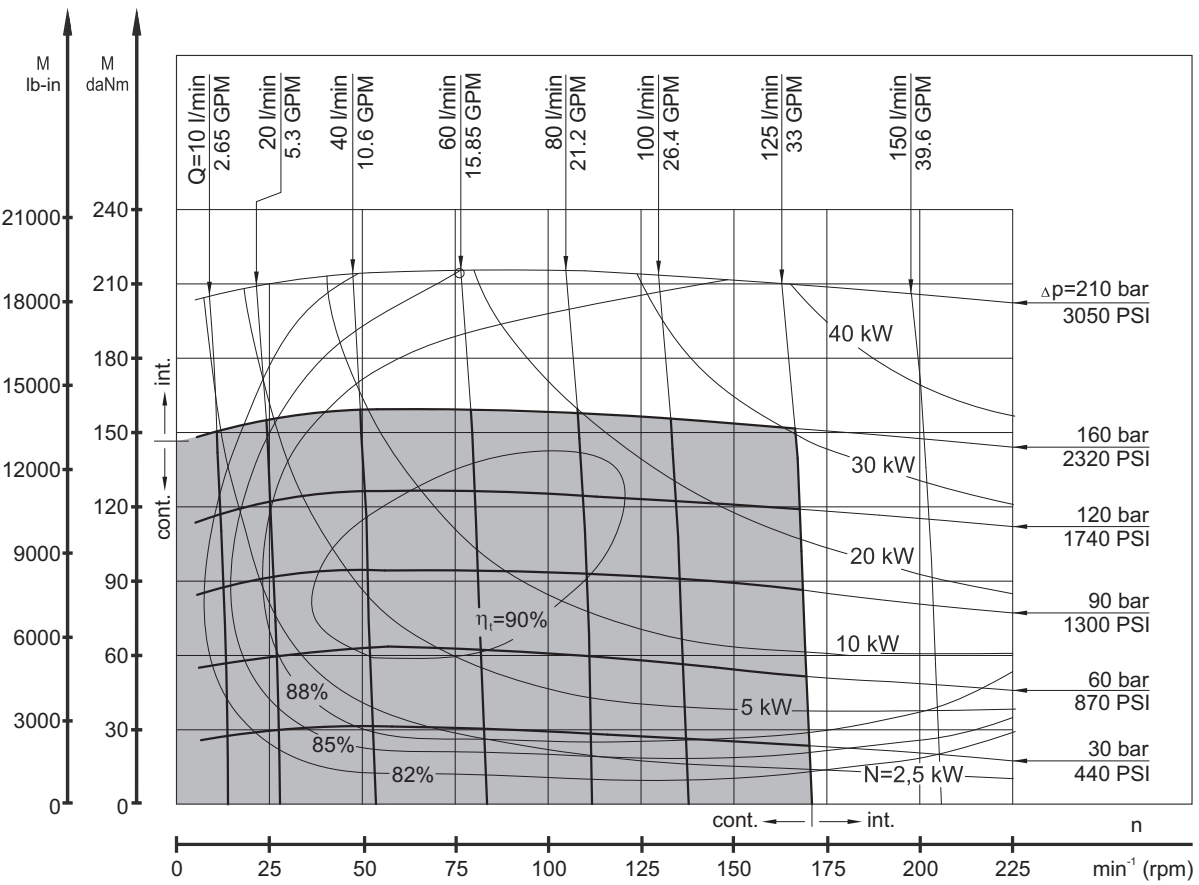

The function diagrams data was collected at back pressure 5÷10 bar (72.5 PSI÷145 PSI) and oil with viscosity of 32 mm²/s [150 SUS] at 50°C [122°F].

DIMENSIONS AND MOUNTING DATA - TMF

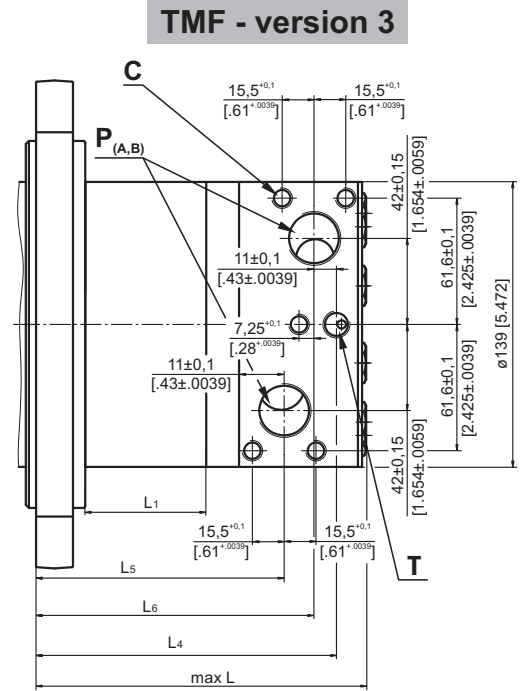
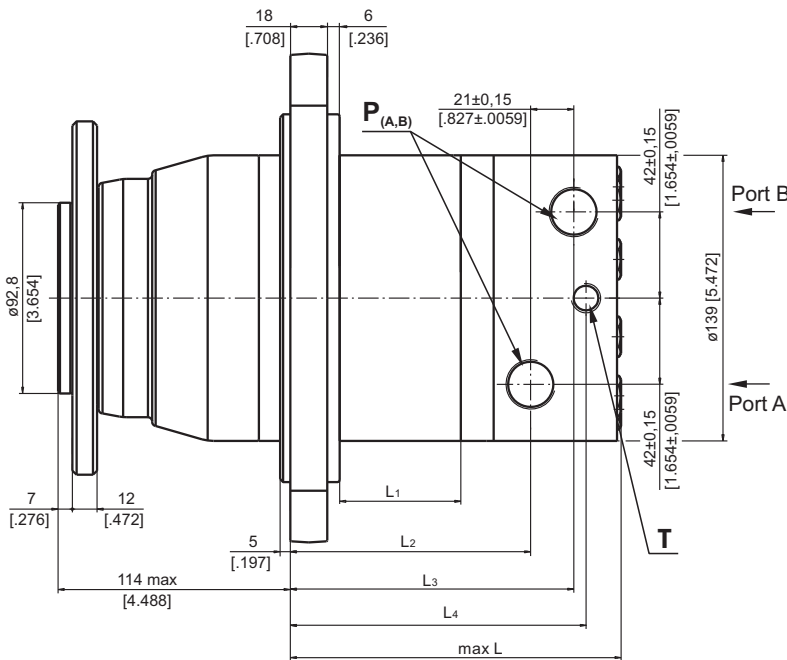
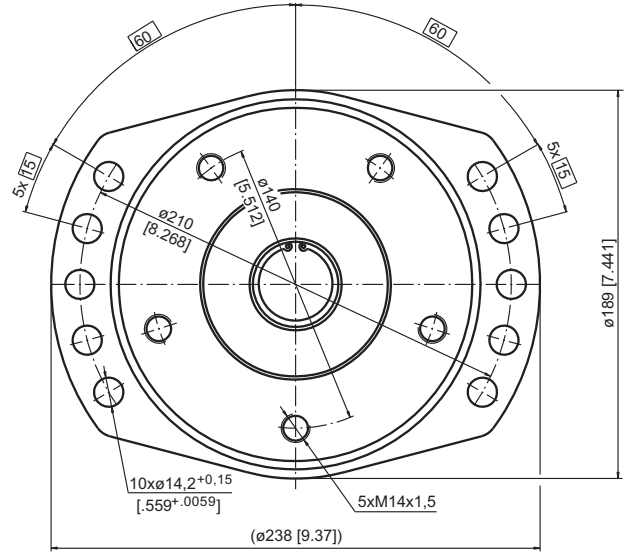
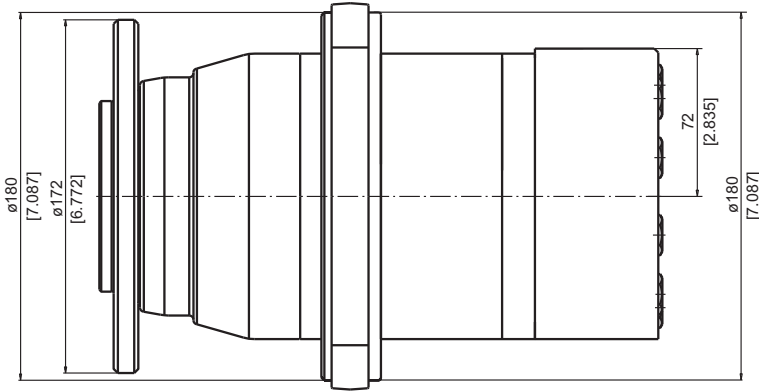

Warning: Drain line should always be used.

	Versions		
	2	3	4
P(A,B)	2xG3/4 17 mm [.669 in] depth	2xG3/4 17 mm [.669 in] depth	2x1 1/16-12 UN 17 mm [.669 in] depth O-ring
T	G1/4 12 mm [.472 in] depth	G1/4 12 mm [.472 in] depth	9/16-18 UN 12 mm [.472 in] depth O-ring
C	-	5xM10 17 mm [.669 in] depth	-



Standard Rotation
Viewed from Shaft End
Port A Pressurized - **CW**
Port B Pressurized - **CCW**

Reverse Rotation
Viewed from Shaft End
Port A Pressurized - **CCW**
Port B Pressurized - **CW**

Type	L, mm [in]	L ₁ , mm [in]	L ₂ , mm [in]	L ₃ , mm [in]	L ₄ , mm [in]	L ₅ , mm [in]	L ₆ , mm [in]
TMF 200	126 [4.96]	25,0 [.98]	83,0 [3.27]	104,0 [4.09]	110,3 [4.34]	87,0 [3.43]	101,5 [3.99]
TMF 250	133 [5.24]	31,3 [1.23]	89,3 [3.52]	110,3 [4.34]	116,6 [4.59]	93,5 [3.68]	108,0 [4.25]
TMF 315	142 [5.59]	40,5 [1.59]	98,5 [3.88]	119,5 [4.70]	125,8 [4.95]	102,5 [4.04]	117,0 [4.61]
TMF 400	152 [5.98]	51,0 [2.01]	109,0 [4.29]	130,0 [5.12]	136,3 [5.37]	113,0 [4.45]	127,5 [5.02]
TMF 470	161 [6.34]	59,0 [2.32]	117,0 [4.61]	138,0 [5.43]	144,3 [5.68]	121,0 [4.76]	135,0 [5.33]
TMF 500	166 [6.54]	65,0 [2.56]	123,0 [4.84]	144,0 [5.67]	150,3 [5.92]	127,0 [5.00]	141,5 [5.57]
TMF 630	162 [6.38]	61,0 [2.40]	119,0 [4.69]	140,0 [5.51]	146,3 [5.76]	123,0 [4.84]	137,5 [5.41]
TMF 725	171 [6.73]	70,0 [2.76]	128,0 [5.04]	149,0 [5.87]	155,3 [6.11]	132,0 [5.20]	146,5 [5.77]

DIMENSIONS AND MOUNTING DATA - TMFA

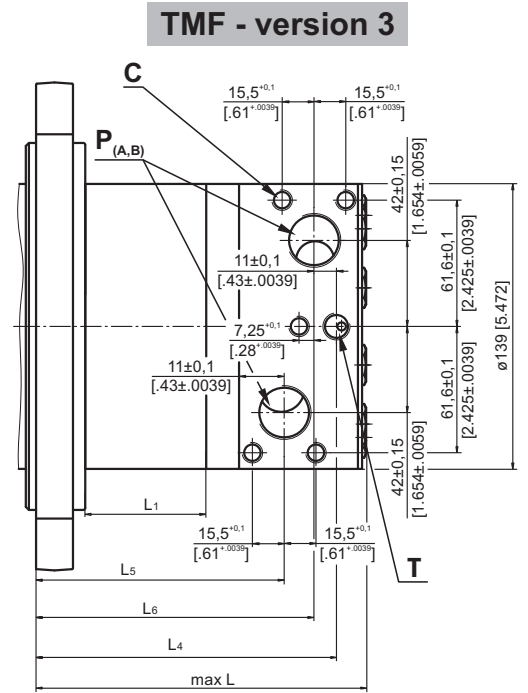
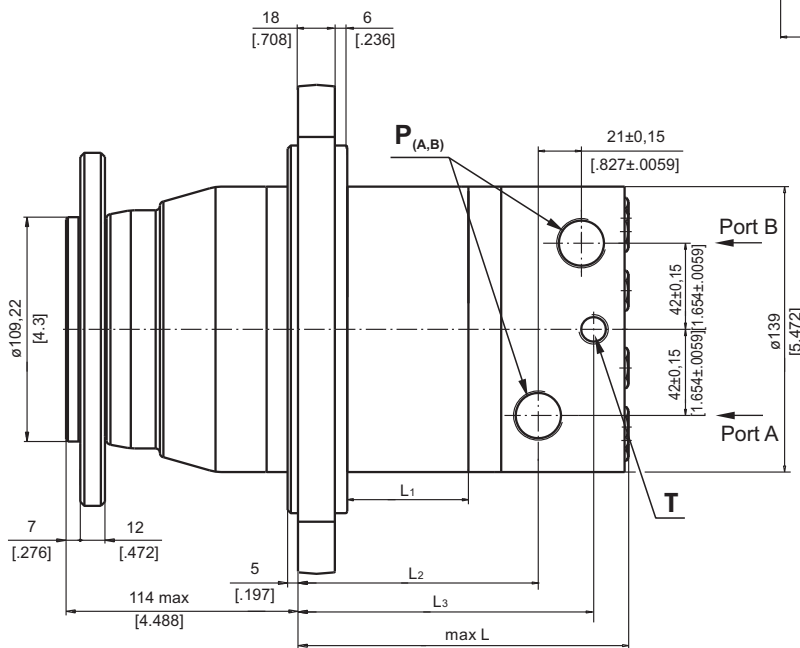
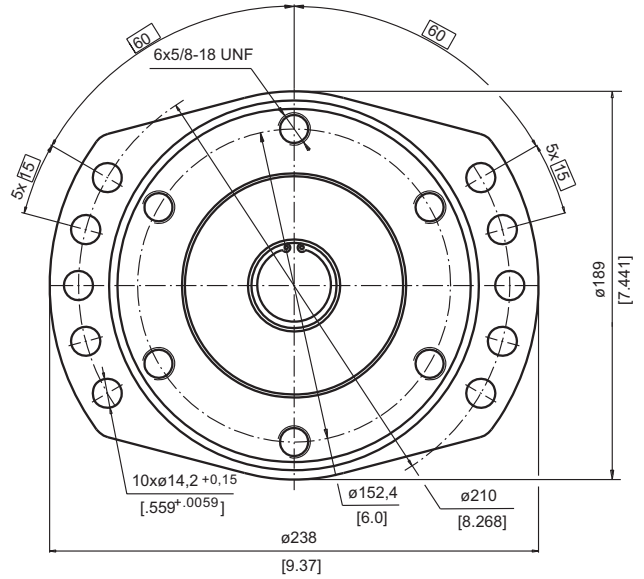
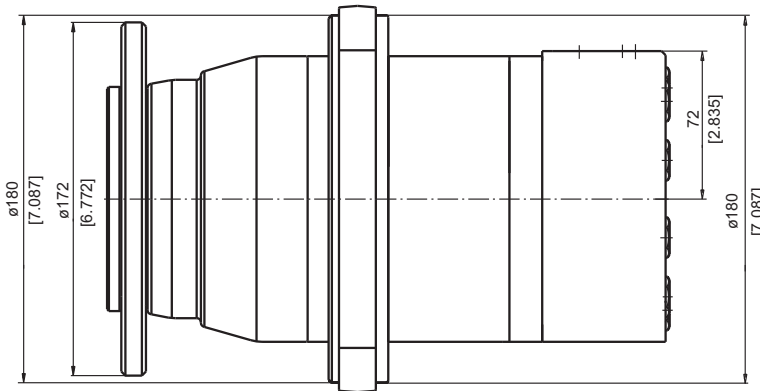

TMF - version 3

Warning: Drain line should always be used.

	Versions		
	2	3	4
P_(A,B)	2xG3/4 17 mm [.669 in] depth	2xG3/4 17 mm [.669 in] depth	2x1 1/16-12 UN 17 mm [.669 in] depth O-ring
T	G1/4 12 mm [.472 in] depth	G1/4 12 mm [.472 in] depth	9/16-18 UN 12 mm [.472 in] depth O-ring
C	-	5xM10 17 mm [.669 in] depth	-



Standard Rotation
Viewed from Shaft End
Port A Pressurized - **CW**
Port B Pressurized - **CW**

Reverse Rotation
Viewed from Shaft End
Port A Pressurized - **CCW**
Port B Pressurized - **CW**

Type	L, mm [in]	L ₁ , mm [in]	L ₂ , mm [in]	L ₃ , mm [in]	L ₄ , mm [in]	L ₅ , mm [in]	L ₆ , mm [in]
TMF 200	126 [4.96]	25,0 [.98]	83,0 [3.27]	110,3 [4.34]	112,5 [4.43]	87,0 [3.43]	101,5 [3.99]
TMF 250	133 [5.24]	31,3 [1.23]	89,3 [3.52]	116,6 [4.59]	118,8 [4.68]	93,5 [3.68]	107,8 [4.24]
TMF 315	142 [5.59]	40,5 [1.59]	98,5 [3.88]	125,8 [4.95]	128,0 [5.04]	102,5 [4.04]	117,0 [4.61]
TMF 400	152 [5.98]	51,0 [2.01]	109,0 [4.29]	136,3 [5.37]	138,5 [5.45]	113,0 [4.45]	127,5 [5.02]
TMF 470	161 [6.34]	59,0 [2.32]	117,0 [4.61]	144,3 [5.68]	146,5 [5.77]	121,0 [4.76]	135,0 [5.33]
TMF 500	166 [6.54]	65,0 [2.56]	123,0 [4.84]	150,3 [5.92]	152,5 [6.00]	127,0 [5.00]	141,5 [5.57]
TMF 630	162 [6.38]	61,0 [2.40]	119,0 [4.69]	146,3 [5.76]	148,5 [5.85]	123,0 [4.84]	137,5 [5.41]
TMF 725	171 [6.73]	70,0 [2.76]	128,0 [5.04]	155,3 [6.11]	157,5 [6.20]	132,0 [5.20]	146,5 [5.77]

PERMISSIBLE SHAFT LOADS

The load diagram is valid for an average bearings life of 2000 hours at 100 RPM

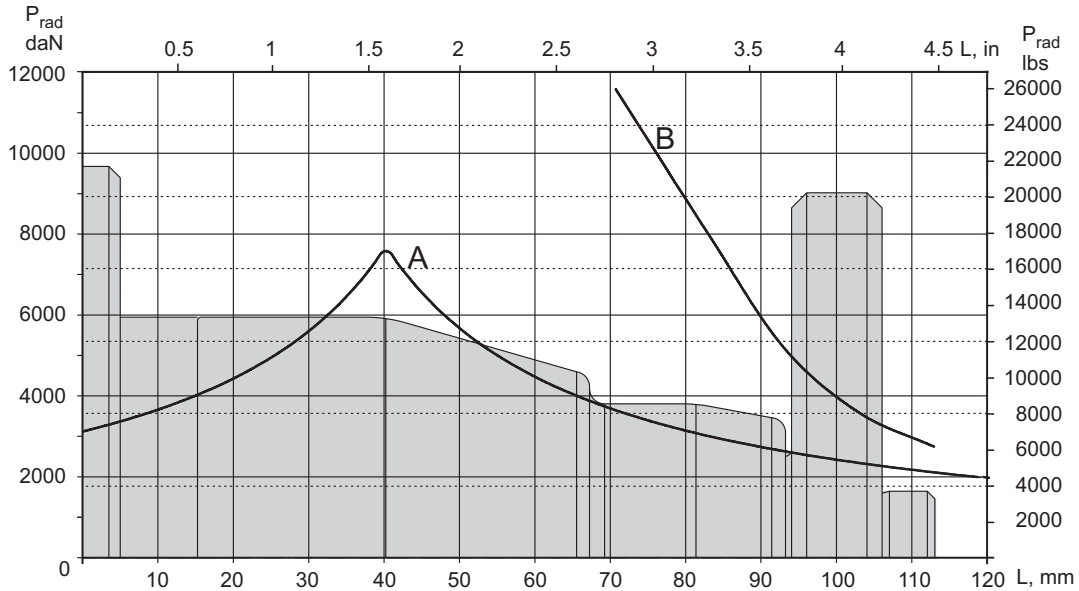

A - Permissible radial shaft load.

B - Max. radial shaft load. Any shaft load exceeding the values shown in the curve will involve a risk of breakage.

ORDER CODE

	1	2	3	4	5
TMF				HD	

Pos.1 - Mounting Flange

omit - Thread hole flange, 5xM14x1,5 on \varnothing 140 [5.512]

A - Thread hole flange, 6x5/8-18 UNF on \varnothing 152,4 [6.0]

Pos.2 - Displacement code

200 - 201,4 cm³/rev [12.29 in³/rev]

250 - 251,8 cm³/rev [15.36 in³/rev]

315 - 326,3 cm³/rev [19.90 in³/rev]

400 - 410,9 cm³/rev [25.06 in³/rev]

470 - 475,0 cm³/rev [28.97 in³/rev]

500 - 523,6 cm³/rev [31.95 in³/rev]

630 - 631,2 cm³/rev [38.52 in³/rev]

725 - 724,3 cm³/rev [44.20 in³/rev]

Pos.3 - Ports

2 - side ports, 2xG3/4, G1/4, BSP thread, ISO 228

3 - side ports, 2xG3/4, G1/4, 5xM10
BSP thread, ISO 228

4 - side ports, 2x1 1/16-12 UN, O-ring, 9/16-18 UNF

Pos.4 - Special Features

HD - Reinforced motor **HD***

For Other **Special Features** [see page 58](#)

Pos.5 - Design Series

omit - Factory specified

NOTES: * Drain line should always be used.

The hydraulic motors are manganophosphatized as standard.