

# HYDROSTATIC STEERING UNITS TYPE HKU.../3, 4

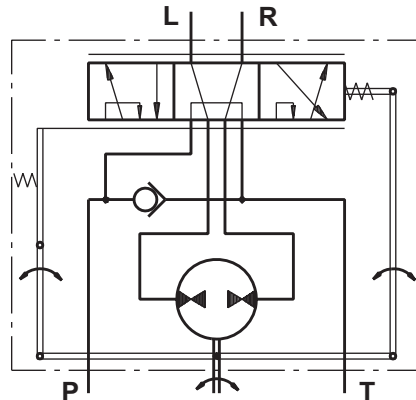

The newly designed HKU steering units, with radial distribution, incorporate two rotary tracing valves in the housing, which turn on the metering pump.



"Open Center - Load Reaction"  
HKU.../3

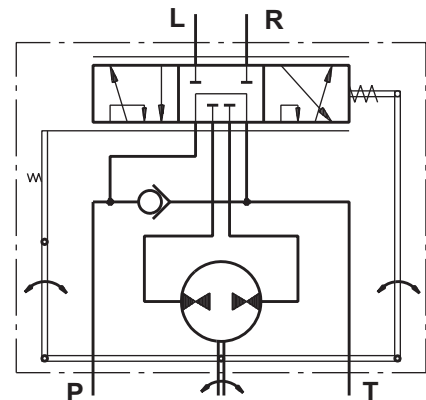

"Open Center - Non Load Reaction"  
HKU.../4

## SPECIFICATION DATA

Parameters	Type																
	HKU	HKU	HKU	HKU	HKU	HKU	HKU	HKU	HKU	HKU	HKU	HKU	HKU	HKU	HKU	HKU	
	40/3	50/3	63/3	80/3	100/3	125/3	160/3	200/3	250/3	320/3	400/3						
	HKU	HKU	HKU	HKU	HKU	HKU	HKU	HKU	HKU	HKU	HKU	HKU	HKU	HKU	HKU	HKU	
Displacement	cm <sup>3</sup> /rev	39,6	49,5	65,6	79,2	99,0	7.56	9.67	198	247,5	316,8	396	495	623,6	793	990	
	[in <sup>3</sup> /rev]	[2.42]	[3.0]	[4.0]	[4.83]	[6.04]	[123,8]	[158,4]	[12.1]	[15.1]	[19.3]	[24.2]	[30.2]	[38.05]	[48.4]	[60.4]	
Rated Flow*	lpm	4	5	6	8	10	13	16	20	25	32	40	50	63	70		
	[GPM]	[1.1]	[1.3]	[1.6]	[2.1]	[2.6]	[3.4]	[4.2]	[5.3]	[6.6]	[8.4]	[10.6]	[13.2]	[16.6]	[18.5]		
Rated Pressure	bar	140					170						140		100		
	[PSI]	[2030]					[2465]						[2030]		[1450]		
Max. Cont. Pressure in Line T	bar [PSI]																
		- standard 25 [363] - high pressure (H option) 40 [580]															
Max. Torque at Servoamplifying	Nm [lb-in]											3,0 [26]					
												- with standard springs 3,0 [26] - with soft springs (LT option) 1,8 [16]					
Max. Torque w/o Servoamplifying	Nm [lb-in]	120 [1065]															
Weight	kg	5,3	5,4	5,5	5,6	5,7	5,8	6,0	6,3	6,5	7,0	7,4	8,0	8,7	9,6	10,6	
	[lb]	[11.7]	[11.9]	[12.2]	[12.4]	[12.6]	[12.8]	[13.2]	[13.9]	[14.3]	[15.4]	[16.3]	[17.6]	[19.2]	[21.2]	[23.4]	
Dimension A	mm	130,85	132,2	133,9	136,2	138,8	142,2	146,8	152,2	158,8	168,2	178,8	192	209,3	232,2	258,6	
	[in]	[5.1]	[5.20]	[5.27]	[5.36]	[5.47]	[5.60]	[5.78]	[5.99]	[6.25]	[6.62]	[7.04]	[7.56]	[8.24]	[9.14]	[10.18]	

\* Inlet flow providing maximum speed of rotation:

- 100 RPM - from HKU40 to HKU630;
- 87 RPM - for HKU800;
- 70 RPM - for HKU1000.

# HYDROSTATIC STEERING UNIT TYPE HKU.../7



The HKU.../7 is a "Closed Center - Non Load Reaction" hydrostatic steering unit, designed for integration into systems with built-in hydroaccumulator, achieving minimal energy losses.

When connecting to a differential cylinder the L and R ports of the steering unit must be connected as follows: L to the greater piston area, and R - to the smaller one.

For the "Closed Center - Non Load Reaction" and "Closed Center - Non Reaction and Load Sensing" steering units is possible to observe Thermal Shock - condition caused when the hydraulic system has operated for some time without turning the steering wheel, causing the fluid in the reservoir and

the system to heat up while the steering unit is relatively cool (i.e. there is more than 500F [100C] difference in the temperature). If, under the condition of Thermal Shock, the steering wheel is turned very quickly, it is possible to experience temporary seizure and have the internal parts of the steering unit damaged. The temporary seizure may be followed by a total free wheeling.

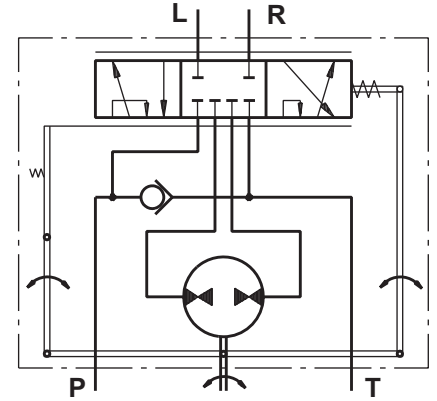

"Closed Center - Non Load Reaction"  
Version 7 - HKU.../7

## SPECIFICATION DATA

Parameters	Type															
	HKU 40/7	HKU 50/7	HKU 63/7	HKU 80/7	HKU 100/7	HKU 125/7	HKU 160/7	HKU 200/7	HKU 250/7	HKU 320/7	HKU 400/7	HKU 500/7	HKU 630/7	HKU 800/7		
Displacement	cm <sup>3</sup> /rev [in <sup>3</sup> /rev]	39,6 [2.42]	49,5 [3.0]	65,6 [4.0]	79,2 [4.83]	99,0 [6.04]	123,8 [7.56]	158,4 [9.67]	198 [12.1]	247,5 [15.1]	316,8 [19.3]	396 [24.2]	495 [30.2]	623,6 [38.05]	793 [48.4]	
Rated Flow*	lpm [GPM]	4 [1.1]	5 [1.3]	6 [1.6]	8 [2.1]	10 [2.6]	13 [3.4]	16 [4.2]	20 [5.3]	25 [6.6]	32 [8.4]	40 [10.6]	50 [13.2]	63 [16.6]	80 [21.1]	
Rated Pressure	bar [PSI]	125 [1810]	140 [2030]	175 [2540]												
Max. Cont. Pressure in Line T	bar [PSI]															
- standard		25 [363]														
- high pressure (H option)		40 [580]														
Max. Torque at Servoamplifying	Nm [lb-in]							3,0 [26]			3,0 [26]					
- with standard springs								3,0 [26]			3,0 [26]					
- with soft springs (LT option)								1,8 [16]			-					
Max. Torque w/o Servoamplifying	Nm [lb-in]	120 [1065]														
Weight	kg [lb]	5,3 [11.7]	5,4 [11.9]	5,5 [12.2]	5,6 [12.4]	5,7 [12.6]	5,8 [12.8]	6,0 [13.2]	6,3 [13.9]	6,5 [14.3]	7,0 [15.4]	7,4 [16.3]	8,0 [17.6]	8,7 [19.2]	9,6 [21.2]	
Dimension A	mm [in]	130,8 [5.15]	132,2 [5.20]	133,9 [5.27]	136,2 [5.36]	138,8 [5.47]	142,2 [5.60]	146,8 [5.78]	152,2 [5.99]	158,8 [6.25]	168,2 [6.62]	178,8 [7.04]	192 [7.56]	209,3 [8.24]	232,2 [9.14]	

\* Inlet flow providing maximum speed of rotation:

- 100 RPM - from HKU40 to HKU630;
- 87 RPM - for HKU800.

**DIMENSIONS AND MOUNTING DATA - HKU.../3, 4, 7**

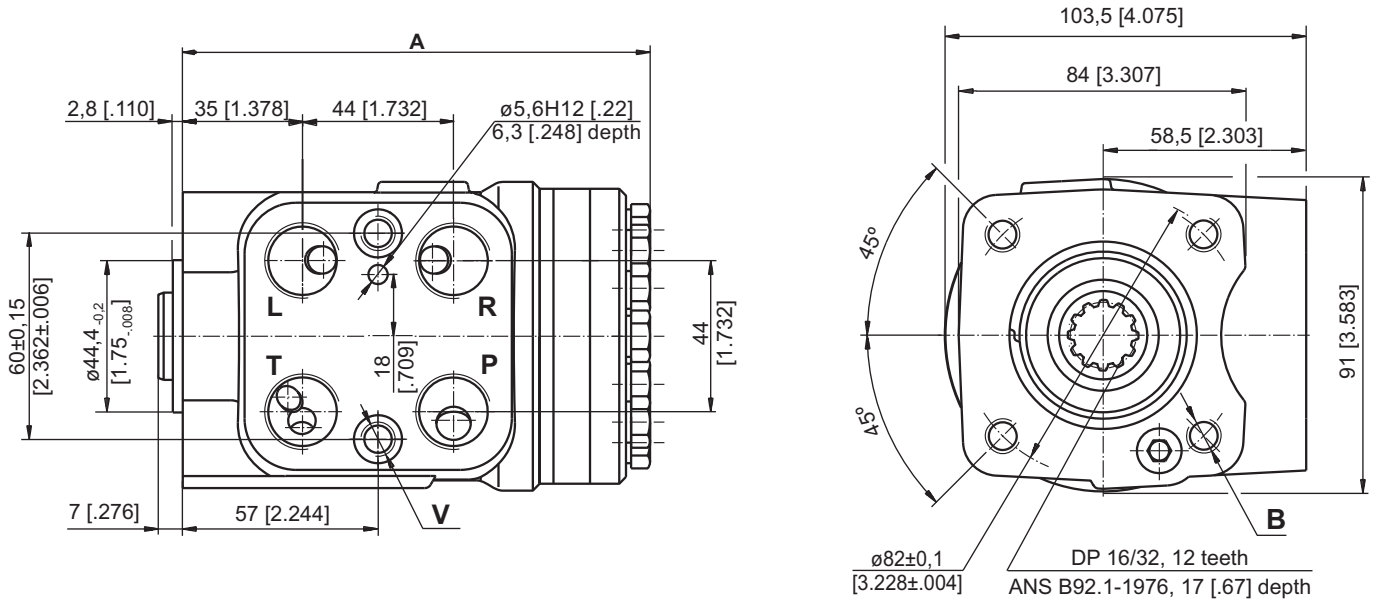

Code	Ports - P, T, R, L Thread	Column Mounting Thread - B	Valve Mounting Thread - V
-	G1/2 17 [.67] depth	4 x M10 18 [.71] depth	2 x M10x1 16 [.63] depth
M	M22x1,5 17 [.67] depth	4 x M10 18 [.71] depth	2 x M10x1 16 [.63] depth
A	3/4 - 16 UNF O-ring 17 [.67] depth	4 x 3/8 - 16 UNC 15,7 [.62] depth	2 x 3/8 - 24 UNF 14,2 [.56] depth
BA*	9/16 - 18 UNF O-ring 17 [.67] depth	4 x 3/8 - 16 UNC 15,7 [.62] depth	2 x 3/8 - 24 UNF 14,2 [.56] depth

\* These threads are for displacements from HKU40 to HKU200 only.

# STEERING UNITS

## ORDER CODE

	1	2	3	4	5	6	7	8
<b>HKU</b>		/	-					

**Pos.1 - Displacement code** (see Specification Data)

- 40** - 39,6 cm<sup>3</sup>/rev [2.42 in<sup>3</sup>/rev]
- 50** - 49,5 cm<sup>3</sup>/rev [3.00 in<sup>3</sup>/rev]
- 63** - 65,6 cm<sup>3</sup>/rev [4.00 in<sup>3</sup>/rev]
- 80** - 79,2 cm<sup>3</sup>/rev [4.83 in<sup>3</sup>/rev]
- 100** - 99,0 cm<sup>3</sup>/rev [6.04 in<sup>3</sup>/rev]
- 125** - 123,8 cm<sup>3</sup>/rev [7.56 in<sup>3</sup>/rev]
- 160** - 158,4 cm<sup>3</sup>/rev [9.67 in<sup>3</sup>/rev]
- 200** - 198,0 cm<sup>3</sup>/rev [12.10 in<sup>3</sup>/rev]
- 250** - 247,5 cm<sup>3</sup>/rev [15.10 in<sup>3</sup>/rev]
- 320** - 316,8 cm<sup>3</sup>/rev [19.30 in<sup>3</sup>/rev]
- 400** - 396,0 cm<sup>3</sup>/rev [24.20 in<sup>3</sup>/rev]
- 500** - 495,0 cm<sup>3</sup>/rev [30.20 in<sup>3</sup>/rev]
- 630** - 623,6 cm<sup>3</sup>/rev [38.05 in<sup>3</sup>/rev]
- 800** - 793,0 cm<sup>3</sup>/rev [48.40 in<sup>3</sup>/rev]
- 1000** - 990,0 cm<sup>3</sup>/rev [60.40 in<sup>3</sup>/rev]

**Pos.2 - Versions**

- 3** - Version 3 "Open Center - Load Reaction"
- 4** - Version 4 "Open Center - Non Load Reaction"
- 7** - Version 7 "Closed Center - Non Load Reaction"

**Pos.3 - Ports**

- omit - BSPP (ISO 228)
- M** - Metric (ISO 262)
- A** - SAE (ANSI B 1.1 - 1982)
- BA\*** - SAE (ANSI B 1.1 - 1982)

**Pos.4 - Max. Cont. Pressure in line T**

- omit - Standard
- H** - High pressure

**Pos.5 - Input torque**

- omit - Standard
- LT\*** - Low

**Pos.6 - Noise level**

- omit - Standard
- LN\*** - Low

**Pos.7 - Option (Paint)\*\*\***

- omit - No Paint
- P** - Painted
- PC** - Corrosion Protected Paint
- PS** - Special Paint\*\*\*\*
- PCS** - Special Corrosion Protected Paint\*\*\*\*

**Pos.8 - Design Series**

- omit - Factory specified

**Notes:**  
 \* Available only for displacement from 40 to 200.  
 \*\* Available only for versions 3 and 4 with displacement from 40 to 200.  
 \*\*\* Colour at customer's request.  
 \*\*\*\* Non painted feeding surfaces, colour at customer's request.

The steering units are mangano-phosphatized as standard.

## ORDER CODE

	1	2	3	4	5	6	7	8	9
<b>HKUS</b>		/	-	-					

**Pos.1 - Displacement code** (see Specification Data)

- 40** - 39,6 cm<sup>3</sup>/rev [2.42 in<sup>3</sup>/rev]
- 50** - 49,5 cm<sup>3</sup>/rev [3.00 in<sup>3</sup>/rev]
- 63** - 65,6 cm<sup>3</sup>/rev [4.00 in<sup>3</sup>/rev]
- 80** - 79,2 cm<sup>3</sup>/rev [4.83 in<sup>3</sup>/rev]
- 100** - 99,0 cm<sup>3</sup>/rev [6.04 in<sup>3</sup>/rev]
- 125** - 123,8 cm<sup>3</sup>/rev [7.56 in<sup>3</sup>/rev]
- 160** - 158,4 cm<sup>3</sup>/rev [9.67 in<sup>3</sup>/rev]
- 200** - 198,0 cm<sup>3</sup>/rev [12.10 in<sup>3</sup>/rev]
- 250** - 247,5 cm<sup>3</sup>/rev [15.10 in<sup>3</sup>/rev]
- 320** - 316,8 cm<sup>3</sup>/rev [19.30 in<sup>3</sup>/rev]
- 400** - 396,0 cm<sup>3</sup>/rev [24.20 in<sup>3</sup>/rev]
- 500** - 495,0 cm<sup>3</sup>/rev [30.20 in<sup>3</sup>/rev]

**Pos.2 - Versions**

- 3** - Version 3 "Open Center - Load Reaction"
- 4** - Version 4 "Open Center - Non Load Reaction"
- 8** - Version 8 "Open Center - Non Load Reaction"

**Pos.3 - Relief Valve Pressure Settings, bar**

**80, 100, 125, 150, 170**

**Pos.4 - Ports**

- omit - BSPP (ISO 228)
- A** - SAE (ANSI B 1.1 - 1982)
- M** - Metric (ISO 262)

**Pos.5 - Max. Cont. Pressure in line T**

- omit - Standard
- H** - High pressure

**Pos.6 - Input torque**

- omit - Standard
- LT\*** - Low

**Pos.7 - Noise level**

- omit - Standard
- LN\*** - Low

**Pos.8 - Option (Paint)\*\*\***

- omit - No Paint
- P** - Painted
- PC** - Corrosion Protected Paint
- PS** - Special Paint\*\*\*\*
- PCS** - Special Corrosion Protected Paint\*\*\*\*

**Pos.9 - Design Series**

- omit - Factory specified

Version	Manual Steering Check Valve	Relief Valve	Inlet Check Valve	Cylinder Relief Valve	Anti-Cavitation Valve
3	•	•	•		•
4	•	•	•	•	•
8	•	•	•		

**Notes:**  
 \* Available only for displacement from 40 to 200.  
 \*\* Colour at customer's request.  
 \*\*\* Non painted feeding surfaces, colour at customer's request.

The steering units are mangano-phosphatized as standard.