

HYDRAULIC MOTORS PK

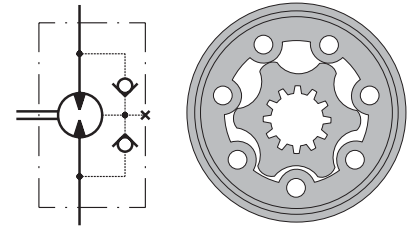

APPLICATION

- » Conveyors
- » Feeding mechanism of robots and manipulators
- » Metal working machines
- » Textile machines
- » Agriculture machines
- » Food industries
- » Mining machinery etc.



CONTENTS

Specification data	59
Dimensions and mounting ...	60
Shaft extensions	61
Order code	61

OPTIONS

- » Model- Spool valve, gerotor
- » Antifriction conical bearing
- » Flange mount
- » Shafts- straight, splined and tapered
- » Metric and BSPP ports
- » Other special features

GENERAL

Max. Displacement, cm ³ /rev [in ³ /rev]	396 [24.16]
Max. Speed, [RPM]	1010
Max. Torque, daNm [lb-in]	cont.: 40,8 [3611] int.: 55,6 [4921]
Max. Output, kW [HP]	8,6 [11.5]
Max. Pressure Drop, bar [PSI]	cont.:105 [1520] int.: 140 [2030]
Max. Oil Flow, lpm [GPM]	50 [13.2]
Min. Speed, [RPM]	10
Pressure fluid	Mineral based- HLP(DIN 51524) or HM(ISO 6743/4)
Temperature range, °C [°F]	-40÷140 [-40÷284]
Optimal Viscosity range, mm ² /s [SUS]	20÷75 [98÷347]
Filtration	ISO code 20/16 (Min. recommended fluid filtration of 25 micron)

Oil flow in drain line

Pressure drop bar [PSI]	Viscosity mm ² /s [SUS]	Oil flow in drain line lpm [GPM]
100 [1450]	20 [98]	2,5 [.660]
	35 [164]	1,8 [.476]
140 [2030]	20 [98]	3,5 [.925]
	35 [164]	2,8 [.740]

Pressure Losses

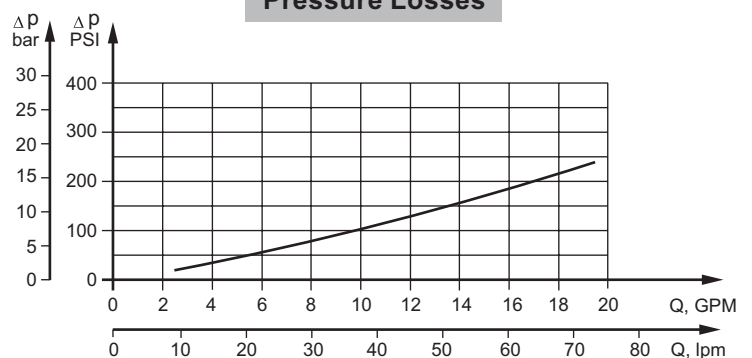

SPECIFICATION DATA

Type	PK 50	PK 80	PK 100	PK 125	PK 160	PK 200	PK 250	PK 315	PK 400	
Displacement, cm³/rev [in³/rev]	49,5[3.02]	79,2 [4.83]	99 [6.04]	123,8 [7.55]	158,4 [966]	198 [12.1]	247,5 [15.1]	316,8 [19.3]	396 [24.16]	
Max. Speed, [RPM]	Cont.	808	505	404	323	252	202	160	100	
	Int.*	1010	630	505	403	315	252	202	126	
Max. Torque daNm [lb-in]	Cont.	7 [619]	10,8 [956]	14,4 [1274]	17 [1504]	22 [1974]	27,5 [2434]	30,1 [2664]	31,7 [2805]	40,8 [3611]
	Int.*	9,2 [814]	14,6 [1292]	18,3 [1619]	22,9 [2026]	29,3 [2593]	36,6 [3239]	37,6 [3328]	44 [3894]	55,6 [4921]
	Peak**	13,6 [1203]	21,4 [1894]	26,1 [2310]	32,6 [2885]	41,8 [3700]	52,2 [4620]	51,5 [4558]	64,3 [5691]	80 [7080]
Max. Output kW [HP]	Cont.	5,2 [7.0]	5,2 [7.0]	5,2 [7.0]	5,2 [7.0]	5,2 [7.0]	5,2 [7.0]	4,6 [6.2]	3,4 [4.6]	3,4 [4.6]
	Int.*	8,6 [11.5]	8,6 [11.5]	8,6 [11.5]	8,6 [11.5]	8,6 [11.5]	8,6 [11.5]	7 [9.3]	5,8 [7.8]	5,8 [7.8]
Max. Pressure Drop bar [PSI]	Cont.	105 [1520]	105 [1520]	105 [1520]	105 [1520]	105 [1520]	105 [1520]	90 [1305]	70 [1015]	70 [1015]
	Int.*	140 [2030]	140 [2030]	140 [2030]	140 [2030]	140 [2030]	140 [2030]	115 [1665]	105 [1520]	105 [1520]
	Peak**	215 [3120]	215 [3120]	215 [3120]	215 [3120]	215 [3120]	215 [3120]	170 [2470]	170 [2470]	170 [2470]
Max. Oil Flow lpm [GPM]	Cont.	40 [10.5]	40 [10.5]	40 [10.5]	40 [10.5]	40 [10.5]	40 [10.5]	40 [10.5]	40 [10.5]	40 [10.5]
	Int.*	50 [13.2]	50 [13.2]	50 [13.2]	50 [13.2]	50 [13.2]	50 [13.2]	50 [13.2]	50 [13.2]	50 [13.2]
Max. Inlet Pressure bar [PSI]	Cont.	140 [2030]	140 [2030]	140 [2030]	140 [2030]	140 [2030]	140 [2030]	140 [2030]	140 [2030]	140 [2030]
	Int.*	175 [2540]	175 [2540]	175 [2540]	175 [2540]	175 [2540]	175 [2540]	175 [2540]	175 [2540]	175 [2540]
	Peak**	225 [3260]	225 [3260]	225 [3260]	225 [3260]	225 [3260]	225 [3260]	225 [3260]	225 [3260]	225 [3260]
Max. Return Pressure with Drain Line or Max. Pressure in Drain Line, bar [PSI]	Cont. 0-100 RPM	150 [2180]	150 [2180]	150 [2180]	150 [2180]	150 [2180]	150 [2180]	150 [2180]	150 [2180]	150 [2180]
	Cont. 100-300 RPM	75 [1090]	75 [1090]	75 [1090]	75 [1090]	75 [1090]	75 [1090]	75 [1090]	75 [1090]	75 [1090]
	Cont. 300-600 RPM	50 [725]	50 [725]	50 [725]	50 [725]	50 [725]	50 [725]	50 [725]	50 [725]	50 [725]
	Cont. >600 RPM	20 [290]	20 [290]	20 [290]	20 [290]	20 [290]	20 [290]	20 [290]	20 [290]	20 [290]
	Int.* 0-max. RPM	15 [220]	15 [220]	15 [220]	15 [220]	15 [220]	15 [220]	15 [220]	15 [220]	15 [220]
Max. Starting Pressure with Unloaded Shaft, bar [PSI]	10 [145]	10 [145]	10 [145]	10 [145]	10 [145]	10 [145]	10 [145]	10 [145]	10 [145]	
Min. Starting Torque, daNm [lb-in]	5,8 [513]	9,1 [805]	12,2 [1079]	14,5 [1283]	19,5 [1725]	24,8 [2195]	27,5 [2433]	29 [2567]	35,9 [3278]	
Min. Speed***, [RPM]	10	10	10	10	10	10	10	10	10	
Weight, kg [lb]	5 [11.1]	5,1 [11.2]	5,3 [11.7]	5,4 [11.9]	5,6 [12.3]	5,8 [12.8]	6 [13.2]	6,3 [13.9]	6,8 [15]	

* Intermittent operation: the permissible values may occur for max. 10% of every minute.

** Peak load: the permissible values may occur for max. 1% of every minute.

*** For speeds lower than given, consult factory or your regional manager.

- Intermittent speed and intermittent pressure must not occur simultaneously.
- Recommended filtration is per ISO cleanliness code 20/16. A nominal filtration of 25 micron or better.
- Recommend using a premium quality, anti-wear type mineral based hydraulic oil HLP(DIN51524) or HM (ISO 6743/4).
If using synthetic fluids consult the factory for alternative seal materials.
- Recommended minimum oil viscosity 13 mm²/s [70 SUS] at 50°C [122°F].
- Recommended maximum system operating temperature is 82°C [180°F].
- To assure optimum motor life fill with fluid prior to loading and run at moderate load and speed for 10-15 minutes.

DIMENSIONS AND MOUNTING DATA

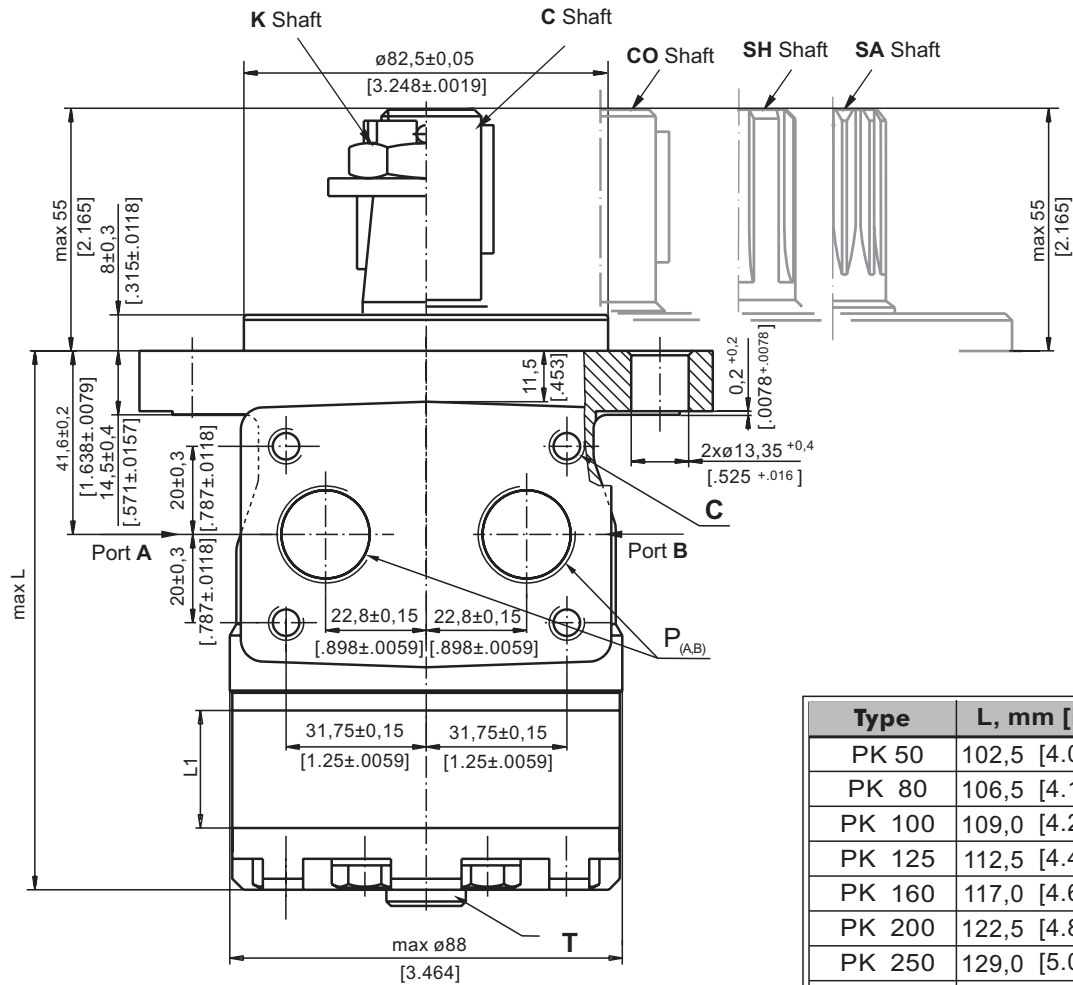

Type	L, mm [in]	L ₁ , mm [in]
PK 50	102,5 [4.04]	6,67 [.26]
PK 80	106,5 [4.19]	10,67 [.42]
PK 100	109,0 [4.29]	13,33 [.52]
PK 125	112,5 [4.43]	16,67 [.66]
PK 160	117,0 [4.61]	21,33 [.84]
PK 200	122,5 [4.82]	26,67 [1.05]
PK 250	129,0 [5.08]	33,33 [1.31]
PK 315	138,5 [5.45]	42,67 [1.68]
PK 400	149,0 [5.87]	53,33 [2.10]

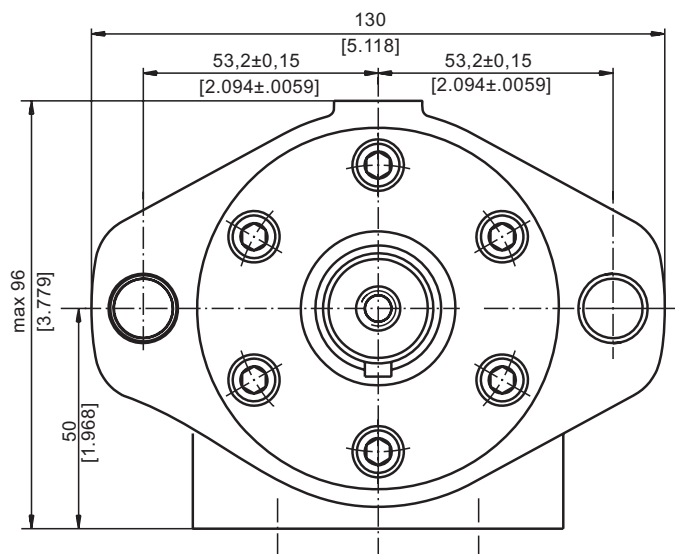

Standard Rotation
Viewed from Shaft End
Port A Pressurized - CW
Port B Pressurized - CCW

Reverse Rotation
Viewed from Shaft End
Port A Pressurized - CCW
Port B Pressurized - CW

- C** : 4xM8 - 13 mm [.51 in] depth
- P_(A,B)** : 2xG1/2 or 2xM22x1,5 - 15 mm [.59 in] depth
- T** : G1/4 or M14x1,5 - 8,5 mm [.33 in] depth (plugged)



SHAFT EXTENSIONS

C - $\varnothing 25$ straight, Parallel key A8x7x32 DIN 6885
Max. Torque 34 daNm [3010 lb-in]

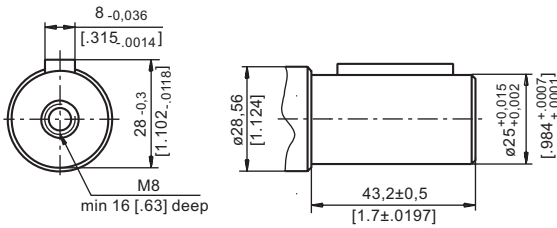

CO - $\varnothing 1"$ straight, Parallel key $\frac{1}{4} \times \frac{1}{4} \times \frac{1}{4}$ " BS46
Max. Torque 34 daNm [3010 lb-in]

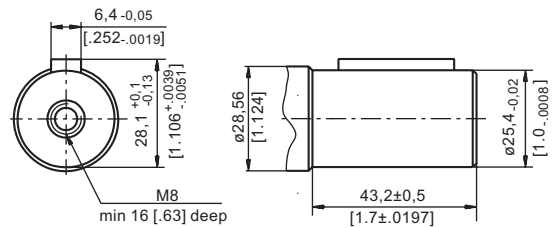

SH - splined, BS 2059 (SAE 6B)
Max. Torque 40 daNm [3540 lb-in]

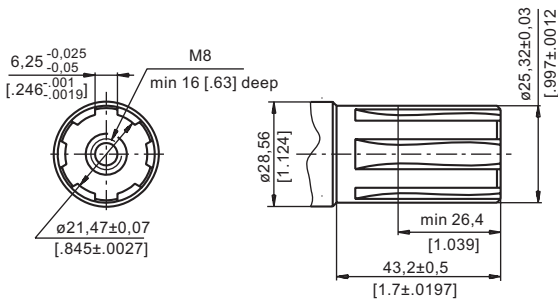

K - tapered 1:10, Parallel key B5x5x14 DIN 6885
Max. Torque 40 daNm [3540 lb-in]

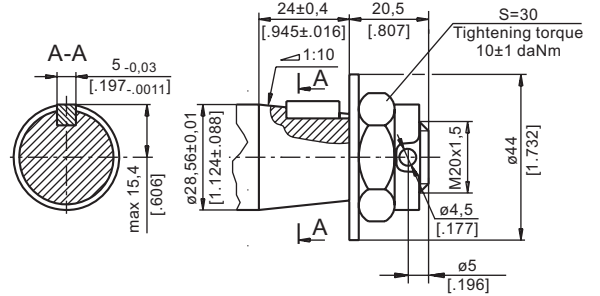

SA - splined, B25x22h9 DIN 5482
Max. Torque 40 daNm [3540 lb-in]

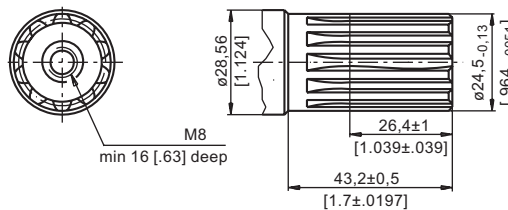

ORDER CODE

	1	2	3	4	5
PK					

Pos.1 - Displacement code

50	- 49,5 cm ³ /rev [3.02 in ³ /rev]
80	- 79,2 cm ³ /rev [4.83 in ³ /rev]
100	- 99,0 cm ³ /rev [6.04 in ³ /rev]
125	- 123,8 cm ³ /rev [7.55 in ³ /rev]
160	- 158,4 cm ³ /rev [9.66 in ³ /rev]
200	- 198,0 cm ³ /rev [12.10 in ³ /rev]
250	- 247,5 cm ³ /rev [15.10 in ³ /rev]
315	- 316,8 cm ³ /rev [19.30 in ³ /rev]
400	- 396,0 cm ³ /rev [24.16 in ³ /rev]

Pos.2 - Shaft Extensions*

C	- $\varnothing 25$ straight, Parallel key A8x7x32 DIN6885
CO	- $\varnothing 25,4$ straight, Parallel key $\frac{1}{4} \times \frac{1}{4} \times \frac{1}{4}$ " BS46
SH	- $\varnothing 25,32$ splined BS 2059 (SAE 6B)
K	- $\varnothing 28,56$ tapered 1:10, Parallel key, B5x5x14 DIN6885
SA	- $\varnothing 24,5$ splined B25x22h9 DIN 5482

Pos. 3 - Ports

omit	- BSPP (ISO 228)
M	- Metric (ISO 262)

Pos. 4 - Special Features (see page 98)

Pos 5 - Design Series

omit	- Factory specified
------	---------------------

NOTE:

* The permissible output torque for shafts must be not exceeded!

The hydraulic motors are manganophosphatized as standard.