

HAND PUMPS MPA...

suitable for oil tank

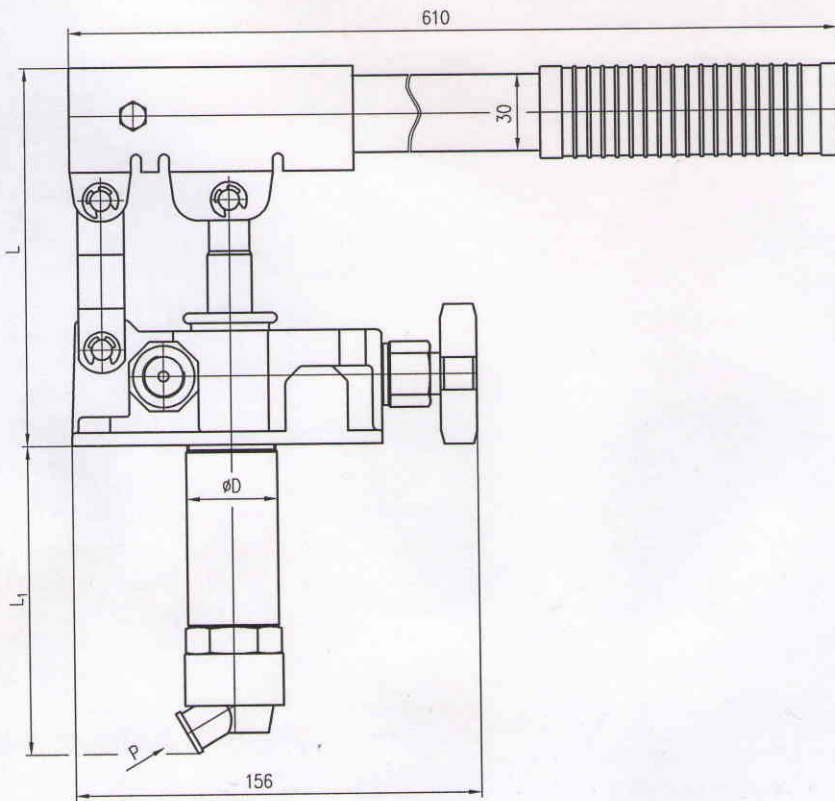

MPA....

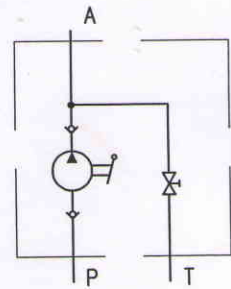

MPA...+RV

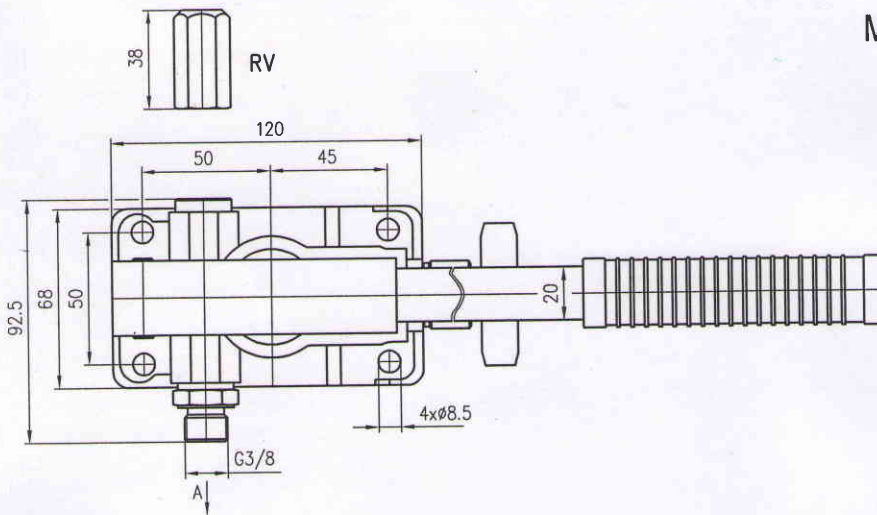
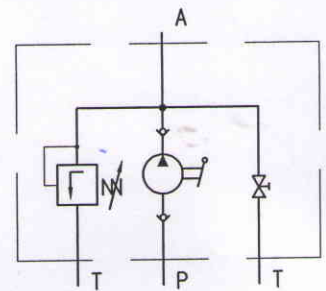

TYPE	Pressure max bar	Vol cm ³	L mm	L1 mm	D mm	Weight kg
MPA12	380	12	147	120	30	3.4
MPA25	350	25	147	120	35	3.7
MPA45	280	45	167	128	40	4.2
MPA12+RV	380	12	147	120	30	3.5
MPA25+RV	350	25	147	120	35	3.8
MPA45+RV	280	45	167	128	40	4.3

*RV—set pressure at 100bar

HAND PUMPS MPC...

suitable for oil tank

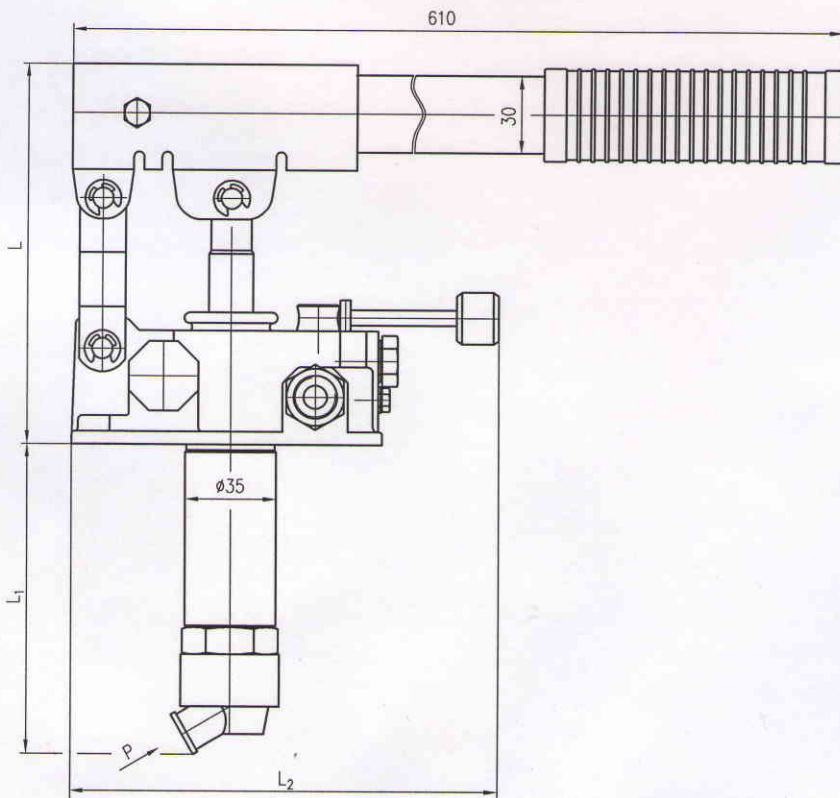

MPC....

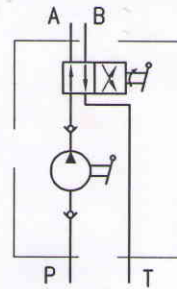

MPC...+RV

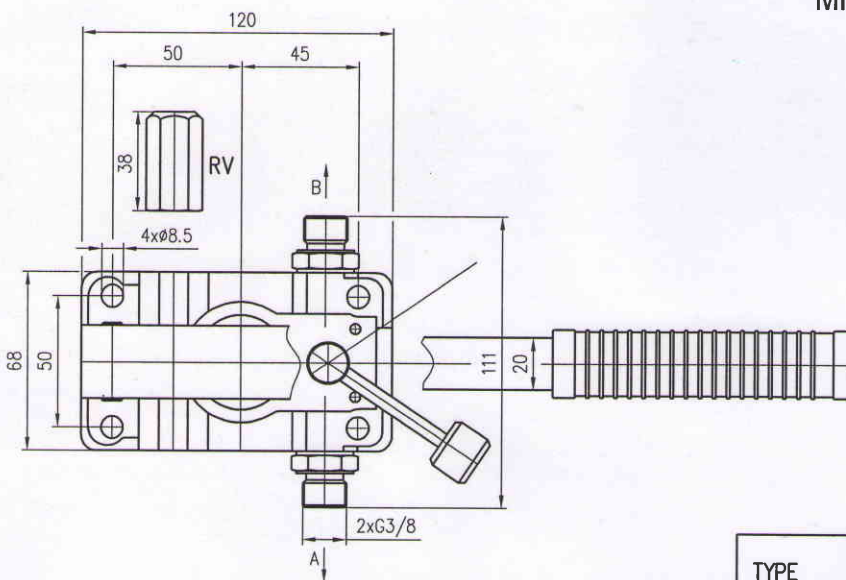
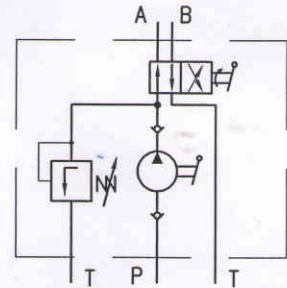

TYPE	Pressure max bar	Vol cm ³	L mm	L1 mm	L2 mm	D mm	Weight kg
MPC12	380	12	147	120	165	30	3.6
MPC25	350	25	147	120	165	35	3.9
MPC45	280	45	167	128	167	40	4.4
MPC12+RV	380	12	147	120	165	30	3.7
MPC25+RV	350	25	147	120	165	35	4.0
MPC45+RV	280	45	167	128	167	40	4.5

*RV-set pressure at 100bar

HAND PUMPS MPE...

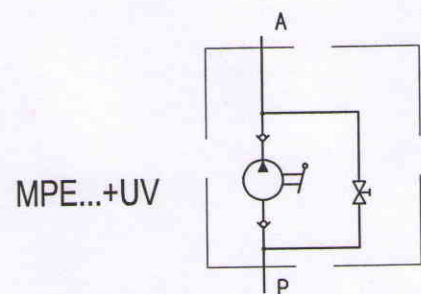
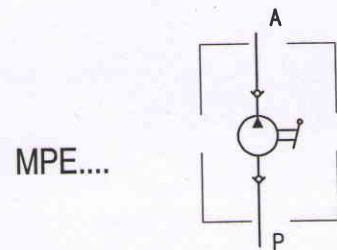
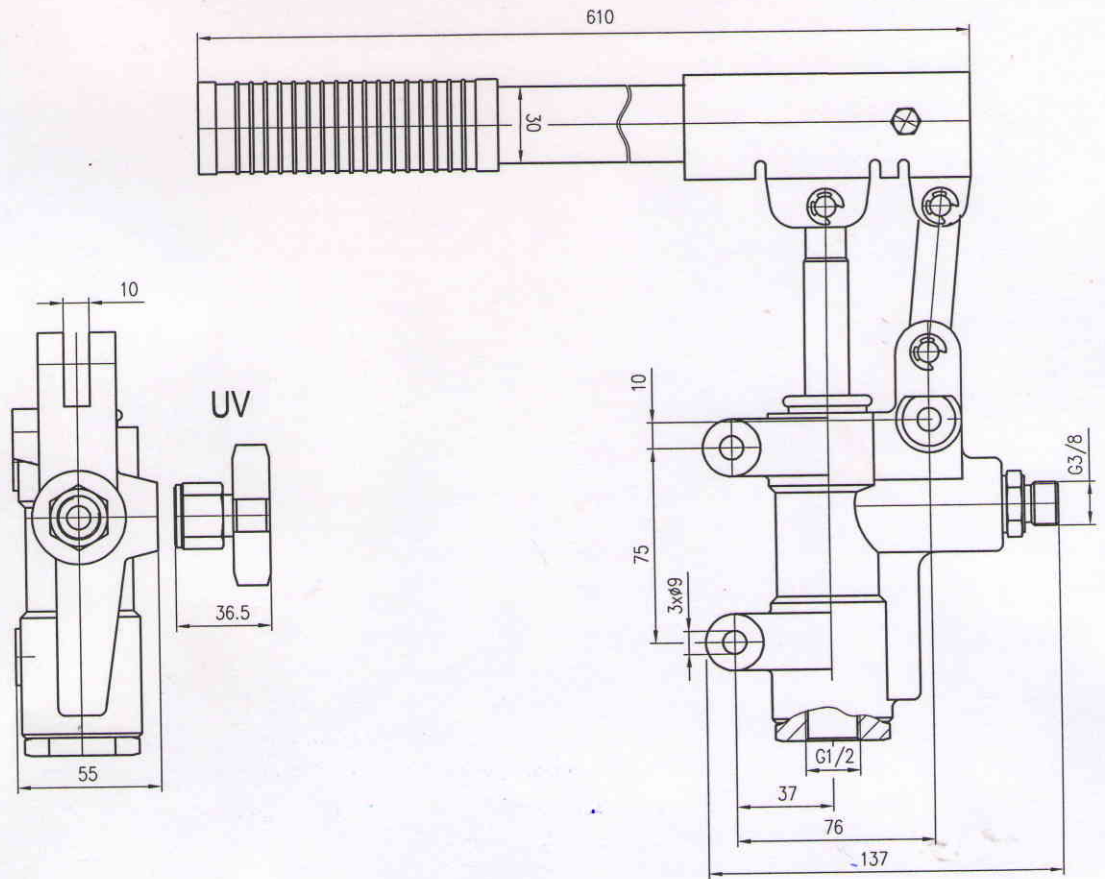

TYPE	Pressure max (bar)	Vol.,cm ³	Weight,kg
MPE20	350	20	3.9
MPE20+UV	350	20	4